



Fuzzy Systems and Applications Evolutionary Genetic Algorithms in the Aviation Industry

Afreen Bhumgara

Alumnus of Nowrosjee Wadia College, India

Abstract-The objective of the research explored the development of Fuzzy Systems and Applications Evolutionary Genetic algorithms in the Aviation Industry, and their demonstrated capability of solving different sets of problem emanating from a wide range of application domains affecting the aviation industry. The research problem statement develop investigated the limitations of approximate reasoning use in cascaded genetic algorithms for automatically generate high performance fuzzy systems used in automated aviation flight control in hazardous flight conditions with using minimal fuzzy sets and rules. The research methodology consisted of qualitative and quantitative research designs through analysis of systematic peer reviewed scholarly journals in the field of Fuzzy Systems and Applications Evolutionary Genetic algorithms in the Aviation Industry, as well as an analysis a sample of relevant case studies. The researcher found out that Fuzzy Systems and Applications Evolutionary Genetic algorithms in the Aviation Industry can be design in a varied number of ways depending on the required shape of the membership functions and appropriate degrees of affinity, and a major limitation of fuzzy inference systems included the limitations concerning the balance between accuracy and interpretability. Therefore, Evolutionary neuro fuzzy inference systems and applications hybridize the approximate reasoning with learning capabilities of evolutionary algorithms and neural networks, which promotes aviation safety personnel capabilities, and aircraft performance. Future research should be devoted in real time planning, and therefore developments should consider more research into delays on airports, weather conditions, and other aviation events that compromise safety and performance such as aviation accidents and attacks.

Keywords- Approximate Reasoning, Aviation Industry, Evolutionary Genetic Algorithms, Fuzzy Rule Sets, Fuzzy Systems, Hybridization, Membership Functions, Neuro Fuzzy Inference Systems, Safety Procedures

I. INTRODUCTION

Fuzzy logic is a concept introduced by Lofti Zadeh in the 1960s, while John Holland introduced genetic algorithms in early 1970s. During the recent past these two fields have experienced enormous rapid growth in academic research and industrial world, by being very effective in finding solutions to real world problems [1]. In conjunction with neurocomputing methodologies have enabled soft computing technologies to be used in intelligent systems that produce human centered fuzzy logic and genetic algorithms. This implies that the modern intelligent systems require the traditional mathematics based, as well as the new computational methodologies that are neural, fuzzy, and genetic algorithm based. Fuzzy systems in automated applications are often made using uncertain ideas, and online human support such as experience and intelligence

often absent implies that definable notions of uncertainty are made so that the automated applications can act like human beings. However, the rules governing the evolution introduce some level of subjectivity in reference to the capability of choosing the attributes of the automated applications and systems [1]. Therefore, fuzzy systems and applications evolutionary genetic algorithms essentially represent the process of linguistic information, as well as the mechanisms and methodologies of dealing with uncertainty coupled with imprecision modeled alongside a concise mathematical model that describes the linguistic rules [4].

A. Background Information

Genetic algorithms for identifying fuzzy systems depends on the high level of non-linearity of the fuzzy systems outputs, and therefore traditional linear optimization techniques bear a number of limitations. It is imperative to note that genetic applications have shown that they are very powerful and robust in performing tasks like generating fuzzy rule bases, membership functions, optimizing fuzzy rule bases, and tuning member functions [3]. This implies that all tasks are optimized through search processes occurring in large solution spaces.

Genetic programming on the fuzzy system identification uses genetic algorithms that are powerful in identifying fuzzy member functions using predefined rule bases. They also display a number of their limitations when applied in identifying both input and output variables of fuzzy system occurring within a given data set. Therefore, genetic programming used in input variables identification applies rule bases involving membership functions of the fuzzy model [10].

Over the last ten years, multi objective genetic fuzzy systems have applied rule based systems in the optimization, and therefore have gathered immense interests among the artificial intelligence community and fuzzy systems practitioners. The rule systems apply stochastic algorithms in multi objective optimization while searching for pareto efficiency. Therefore, objectives are optimized simultaneously thus making them highly accurate and complex, as well as accurate and interpretable [4].

Fuzzy systems therefore, are applied in situations where conventional techniques are not successful or require too much time for the development. Non-linear models, time variable parameters, as well as places where pertinent mathematical models are unknown. This implies that fuzzy systems play a great role in pattern recognition, decision support systems, plant control, solving electromagnetic

field problems, aviation flight control, genetic learning of databases, telecommunications, and many other applications [5].

B. Research Aims and Objectives

The aim of the research is to explore the development of Fuzzy Systems and Applications Evolutionary Genetic algorithms in the Aviation Industry, and their demonstrated capability of solving different sets of problem emanating from a wide range of application domains affecting the aviation industry. In recent years the application of approximate reasoning have continued to evolve, and there are a number of inherent limitations that still faces the utilization of Fuzzy Systems and Applications Evolutionary Genetic algorithms methodologies in the Aviation Industry during hazardous airspace conditions. Therefore, the paper aims to analyze the performance and optimization of population based methods, and nature inspired algorithms. The researcher developed the following objectives in investigating the limitations of Fuzzy Systems and Applications Evolutionary Genetic algorithms in the Aviation Industry:

1. Provide account for Fuzzy Systems and Applications Evolutionary Genetic algorithms in the Aviation Industry with special focus of genetic fuzzy rule based structures
2. Provide account for soft computing paradigms of fuzzy systems with the use of evolutionary algorithms with learning data and adaptive capabilities
3. To analyze the interpretability accuracy trade of multiobjective based fuzzy systems for multidimensional learning data problems
4. To discover the problems and issues in the hybridization between genetic algorithms and fuzzy logic with special attention to extracting interesting useful patterns in data
5. To understand the application of evolutionary genetic fuzzy system in aviation aircraft control in hazardous conditions.

C. The Problem Statement

The problem is to investigate the limitations of approximate reasoning use in cascaded genetic algorithms for automatically generate high performance fuzzy systems used in automated aviation flight control in hazardous flight conditions with using minimal fuzzy sets and rules. Such cascaded genetic algorithms should be valuable within complex systems that cannot be either designed or optimized manually both for commercial and military aviation flight systems with aims of eliminating the role of pilots from the aircrafts.

Helicopters have applied fixed wing drone for many years particularly in the military Fuzzy systems and applications Evolutionary Algorithms Genetic algorithms aircraft designs. In many cases military aviation applications are instances of maneuvering tight positions, as well as required to consistently maintain certain positions over longer periods of time. It is important to note that

helicopters are more complex to control as compared to the fixed winged aircrafts.

The complexity and difficulties of developing controllers for non-fixed wing aircraft emanates from the inherently high levels of instability, as well as high degrees of coupling. This implies that it is less difficult and complex for pilots to releases fixed winged aviation aircraft into steady flight conditions, which is a contradiction to helicopters that requires constant and consistent corrective control inputs. It is important to note that coupling in non-fixed wing aviation aircraft requires flight dynamic that vary with type of aircraft, flight region, and the level of gyroscopic moments coming from the main rotor.

D. Research Questions

The researcher developing the following research questions to help in achieving the aims and objectives of the study, as well as to develop the research hypothesis.

1. What are the limitations of fuzzy systems in finding optimal solutions for aircraft control in hazardous conditions?
2. What are the benefits of genetic fuzzy systems in relation to the rule based system?
3. Which are the most appropriate designs of population based search algorithms used in conducting the fuzzy controllers and trajectory tracking in adverse flight conditions?
4. What are the performance approaches for airflow stabilization systems of genetic algorithm in finding premise for constructing rule base?
5. What are the benefits of Multiobjective identifying fuzzy inference systems in space search algorithm?
6. What are the accuracy and interpretability tradeoffs of fuzzy rule structures in the utilization of Multiobjective Genetic Algorithms?
7. How can novel interpretability index be exploited in learning concurrently data in fuzzy rule based systems?
8. What are the design factors in applying Multiobjective evolutionary algorithms in fuzzy autopilots?
9. What is the future research direction for the application of Fuzzy Systems and Applications Evolutionary Genetic algorithms in the Aviation Industry

E. Research Methodology and Design

The researcher applied qualitative and research methods to examine the limitations of by analyzing most recent peered reviewed scholarly journals. The researcher performed literature review from existing online libraries to select the latest journals in the topic under study. Furthermore, a case study analysis approach was employed in investing the performance factors for optimization of fuzzy systems in aircraft control. Sampling for the case studies considered a selection of five samples against a population of 10,000 cases internationally, sampling being done by objective sampling. Data analysis consisted of functions affecting performance of fuzzy systems in the aviation industry

through stochastic processes in order to draw mathematical equations and variables for performance measurements. Analysis of the literature review provides the past, current, and emerging trends in Fuzzy Systems and Applications Evolutionary Genetic algorithms in the Aviation Industry, and therefore is significant for provoking further research.

II. LITERATURE REVIEW

A. Membership Functions and Fuzzy Sets

According to classical set theory considers universal discourse X having a subset A with arbitrary element $x \in X$ mutually belonging to either A or not A, which implies that $x \in A^c$ [10].

That is to say the classical concept is represented by

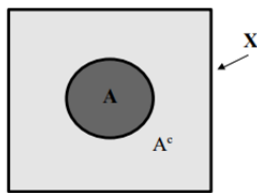

Fig 1: Fuzzy Classical Set Concept

Then assigning a characteristic function $K_A : X \rightarrow \{0,1\}$, which can only assume two crisp numerical values 0 or 1

$$K_A(x) = \begin{cases} 1, & \text{if } x \in A \\ 0, & \text{otherwise} \end{cases} \quad (1)$$

It can be seen that $K_{A^c} = 1 - K_A$ since K_A is an ambiguous characteristic function that identifies elements of A from the rest of X ($A^c = X \setminus A$).

Therefore, A is distinguished from the rest using the pair (X, K_A) that forms the human reasoning of uncertain linguistic operations that $A \leftrightarrow (X, K_A)$.

It is important that an aviation flight conditions such as temperature will be viewed subjectively by different people. For instance, a temperature of 9 can be seen as cold, comfortable, cool, hot, or warm, and therefore a temperature of 9 does not precisely mean the same since its interpretation comes in a subjective manner [7].

It is imperative that in automated systems such uncertain linguistic expressions should define inferences that apply such uncertain ideas on both intelligence and experience of human online support that is absent, should make a useful case for defining notions of uncertainty. Therefore, rules of operations are required to be worked out that manipulates uncertain definitions in order to make the automated systems operates similar to human beings [13].

The notion of the fuzzy set makes it possible to define ideas of uncertainty by offering rules to be chosen from in order to obtain subjective attributes of development of automated systems used in defining aviation industry metrological factors such as temperature, turbulence, convention, humidity, latitude, and so on [7].

Therefore, by describing the uncertain linguistic ideas of the fuzzy set used in automated aviation aircraft systems, such as attaching a temperature interval of $[-10^\circ\text{C}, +10^\circ\text{C}]$ to a linguistic variable comfortable. It is apparent that at the middle of the interval that is possibly surely (comfortable at 1), which implies that the likelihood of comfortable gradually reduces towards the interval boundaries. That is from 1 and slowly towards 0, and hence as the temperature gradually approaches to the center of the interval's boundary means that it is most likely not comfortable outside the interval (comfortable at 0). It is imperative that the fuzzy set is hence attached to comfortable linguistic variable that is defined by $\mu_{\text{comfortable}}: [-10^\circ\text{C}, +10^\circ\text{C}] \rightarrow [0,1]$ that refers to the membership function of the temperature fuzzy set [7].

Given that X refers to the universe of discourse, implies that A defines a fuzzy set on X, therefore the level to which elements that belong to X, that is $x \in X$ belonging to A. This implies that it is defined by $\mu_A(x) \in [0,1]$. Therefore, μ_A is a fuzzy membership function that replaces K_A , which is a crisp characteristic of the temperature interval function. This implies that the fuzzy set A is then identified by the pair (X, μ_A) , and hence the fuzzy set $A \leftrightarrow (X, \mu_A)$ [6]. Approximate reasoning is represented by the primary knowledge of the idea of linguistic variable of temperature comfortable. Therefore, it is important to note that the linguistic variable is identified by values of intrinsic words, phrases, and sentences that are either applied in a natural or artificial language. Hence, the fuzzy set is not represented by numerical values but are of linguistic nature, and is usually associated with 5-tuplen idea of linguistic variable $(x, LX, \dot{LX}, X, M_x)$ [7].

Using a temperature of:

$$\begin{aligned} X = 9 \\ LX &= \{X^{\text{cold}}, X^{\text{cool}}, X^{\text{comfortable}}, X^{\text{warm}}, X^{\text{hot}}\} = \{\text{cold, cool, comfortable, warm, hot}\} \\ \dot{LX} &= \{X^{\text{cold}}, X^{\text{cool}}, X^{\text{comfortable}}, X^{\text{warm}}, X^{\text{hot}}\} \\ X &= [-10^\circ\text{C}, +25^\circ\text{C}] \\ M_x &= \{X^{\text{cold}} \rightarrow X^{\text{cool}}, X^{\text{cool}} \rightarrow X^{\text{comfortable}} \dots \dots X^{\text{hot}}\} \quad (2) \end{aligned}$$

Therefore, assigned fuzzy set and linguistic variable is not distinguished such as comfortable $\leftrightarrow (X, \mu_{\text{comfortable}})$ fuzzy sets can either be discrete or continuous such as

$$A = \sum_{i=1}^n \mu_A(x_i) / x_i$$

Or

$$A = \int_{x \in X} \mu_A(x) / x \quad (3)$$

Discrete membership functions are defined by symbolic sum, while continuous membership functions are defined by scalar variable. Therefore, considering a piecewise linear function or a Gaussian distribution curve are described by the typical membership functions below.

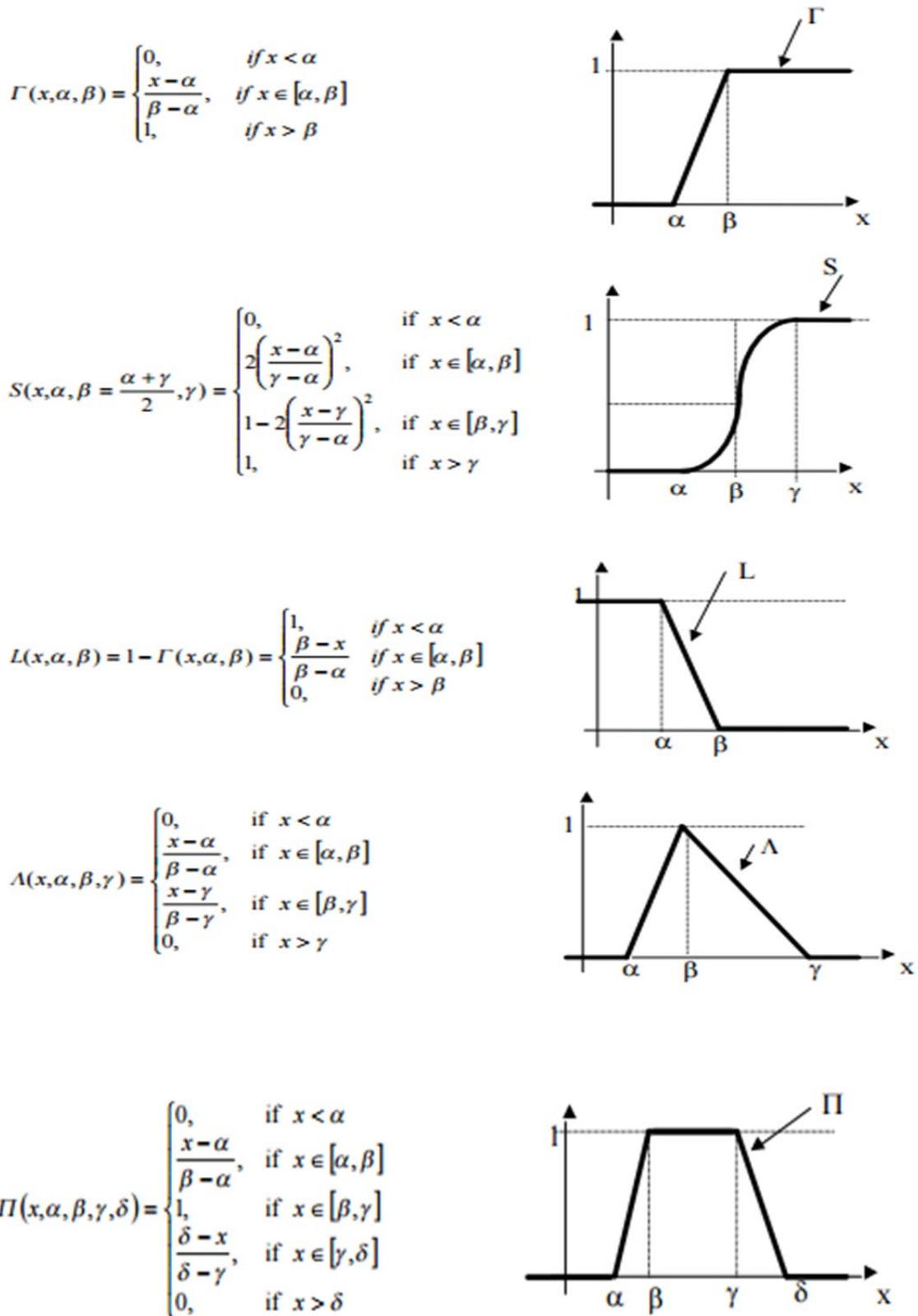

Fig 2: Fuzzy Discrete and Continuous Membership Functions

Therefore, the fuzzy set is normalized by a physical value in order to distinguish the linguistic variables using (p = positive, N = negative), while magnitude uses (B = big, M = medium, S = small, Z = zero), which gives the equipartition regions at 7 levels is represented by

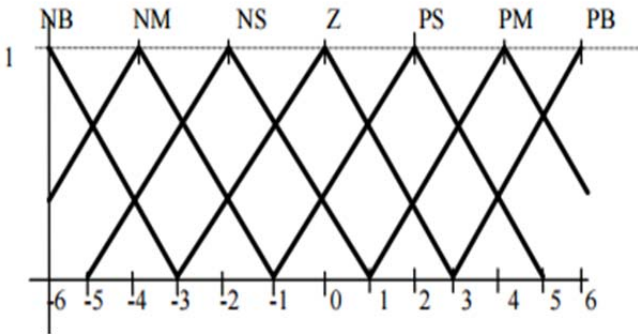

Fig 3: Equipartition Regions at 7 Levels

Equipartition regions at 13 levels is represented by

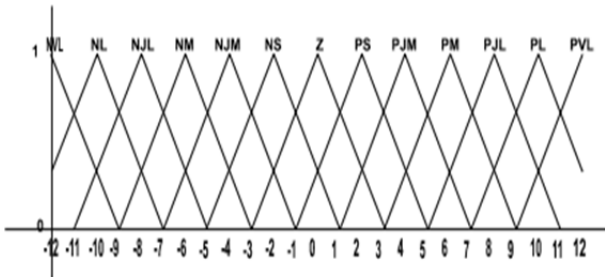

Fig 4: Equipartition Regions at 13 Levels

Non uniform partition regions at 5 levels is given by

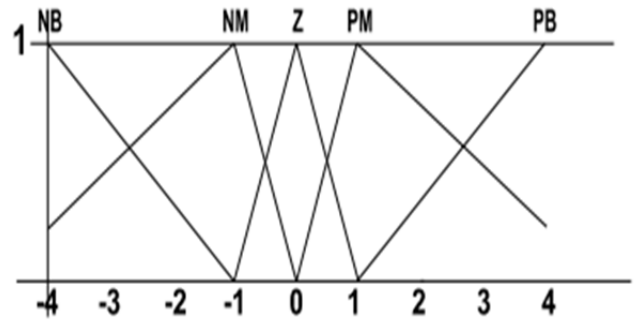
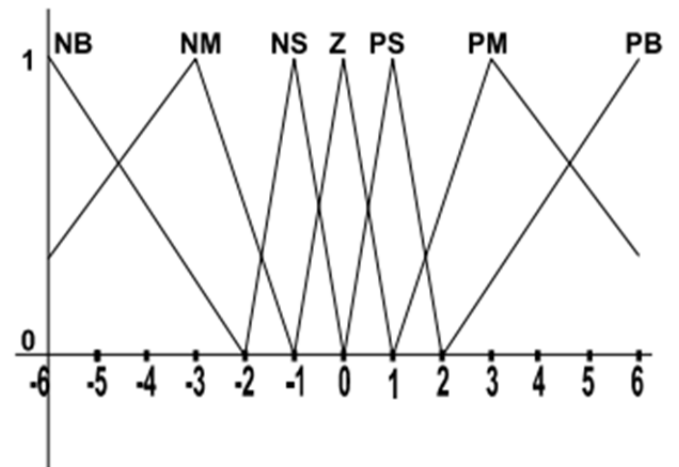

Fig 5: Non Uniform Partition Regions at 5 Levels
Non uniform partition regions at 7 levels is given by

Fig 6: Non Uniform Partition Regions at 7 Levels



Non uniform partition regions at 13 levels is given by

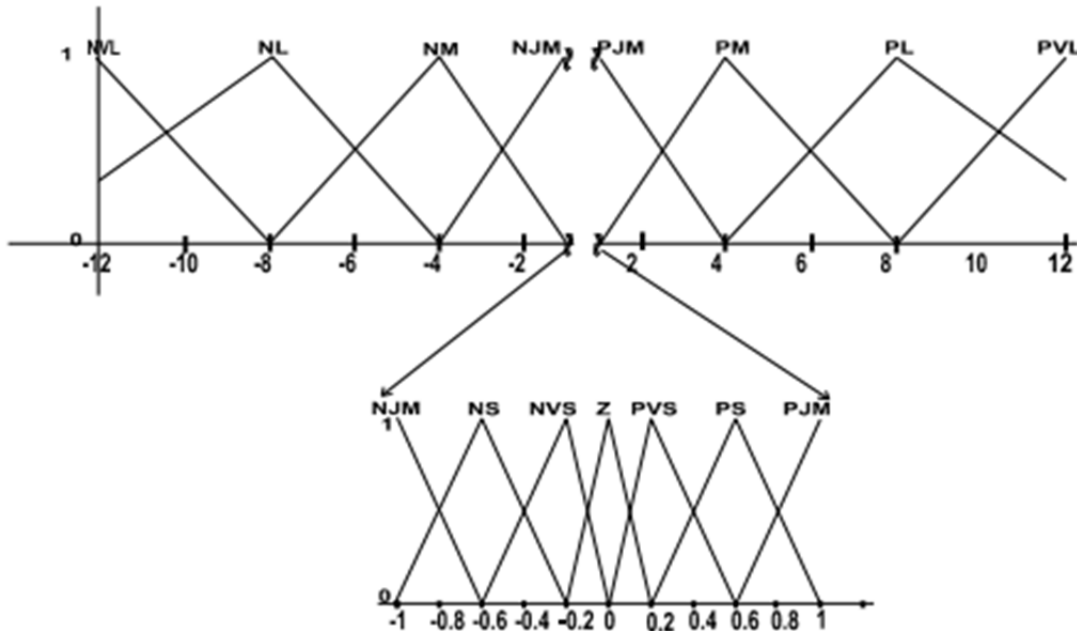

Fig 7: Non Uniform Partition Regions at 13 Levels

Bell type and Gaussian shaped membership functions are typical in describing the fuzzy set linguistic values in a continuous manner, and therefore

Gaussian membership function:

$$\mu(x) = e^{-\frac{1}{2} \left(\frac{x-\bar{x}}{\sigma} \right)^2}, \quad \bar{x} \text{ is the center and } \sigma \text{ is the width.} \quad (4)$$

Generalized bell membership function:

$$\mu(x) = \frac{1}{1 + \left| \frac{x-\bar{x}}{a} \right|^{2b}}, \quad \bar{x} \text{ is the center and } a, b \text{ define the width.}$$

B. Fuzzy Logic Control Optimization Architecture

The fuzzy logic control optimization architecture is developed in order to obtain an aggressively effective, easily adaptable, and computational efficient cascaded genetic algorithms using minimal fuzzy sets and operational rules. Considering the hazardous flight conditions, the automated high performance fuzzy systems for both helicopters and fixed winged aircrafts should have controllers that are able to easily adapt faster to various linguistic variable conditions, as well as smoothly moving the aircraft from one steady flight condition to another. Therefore, the fuzzy logic controller should effectively perform several sets of maneuvers such as stable velocity, acceleration, steady turns, and steady decelerations depending on the linguistic variables. The Fuzzy systems and applications Evolutionary Algorithms Genetic algorithms should be able accomplish required tasks in a desirable manner making the controller of the aircraft as independent as possible [20].

Fuzzy systems and applications Evolutionary Algorithms Genetic algorithms control optimization should address the concerns of a specific architecture in achieving the desirable goals. The architecture’s main function is to determine the state of flow of information that can easily be manipulated in order to take advantage of the artificial intelligence of the fuzzy system. This implies that fuzzy controller logic specializes for specific parts of the system through which the information flows, and therefore every section copes with addressing the linguistic variables of the state of the air flight air space [14].

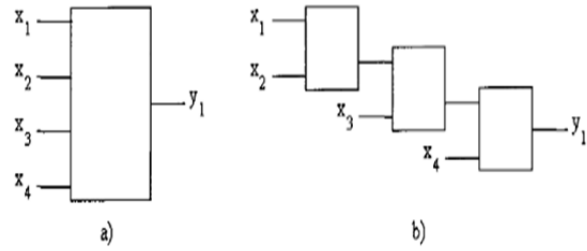

Fig 8: The Fuzzy Controller Blocks

The fuzzy controller then consists of blocks where input of each flight state variables, as well as output of every control section. Such architecture takes care of the related inputs using rules found in the operational rules base. For larger problems the classical approach for developing the fuzzy controller systems appears impractical, and therefore the distributed architecture becomes a better option since the number of rules in the former increases exponentially [13].

However, it is important to note that selecting a suitable architecture is often complex and difficult, which implies that explicit knowledge of the specific dynamics of the fuzzy system is required in diving control tasks that requires minimal operational rules. However, a lot of care is needed in preserving the pertinent relationships between all air space state variables by making an informed balance between having fewer rules, as well as accurate representation of coupling [13].

The fuzzy blocks controls the cyclic longitudinal motion by inferring the changing latitude, and hence the switches determines the control strategies depending on the two error forward velocity as compared to the goal; velocity. The acceleration block determines the error pitch that infers the pitch angle. The architecture simulates a real pilot by longitudinal hold bold analyzing the desired pitch angle. However, the collective control for all linguistic variables the fuzzy switches should determine the simplest and most effective fuzzy logic control optimization architecture [13]. Fuzzy systems and applications Evolutionary Algorithms Genetic algorithms search implementation uses genetic algorithm to arrange rule bases for the aviation aircraft fuzzy logic controller that applies classic genetic operation consisting of mutation, reproduction, and crossover. Therefore, the fuzzy logic system addresses the coding parameters and development of goodness of fit functions. The minimum and maximum values correspond to units of integrated weighted sums of desired set states and summed errors over a simulation course [14].

III. CASE STUDIES

Aircraft control systems applying fuzzy logic case studies compares several fuzzy inference systems through the demonstration of rule bases and fuzzy methods used. The case studies also aim at investigating the contributions of fuzzy logic in industrial applications, and examine the methodologies related to the purposes of this research paper.

Case Study 1: Robot Head Visual Tracking

The case study displays how human faces are tracked through the application of fuzzy proportional derivative referred to as fuzzy condensed algorithm. The system applies fuzzy proportional derivatives in controlling the robot head movement that automatically tracks human faces. The system used software items such as vision and control programs written in C++ and Mathworks' Simulink, as well as hardware items such as USB Webcam and Robot head [16]. The fuzzy proportional derivative inference system is represented by:

Fig 9: Robot Head Visual Tracking

Where G_e , G_r , and G_u are determined through tuning their corresponding error, error rate gains, and output gains, and U^* represents the defuzzified output. The four fuzzy rules bases for the fuzzification are given by:

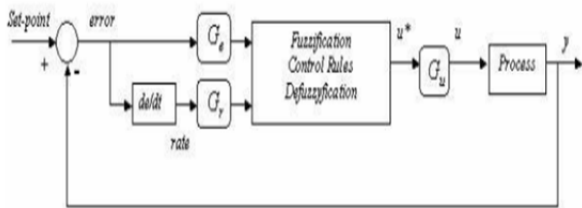

- Rule 1:** If error is e_p and rate is r_p , then output is o_p .
- Rule 2:** If error is e_p and rate is r_n , then output is o_z .
- Rule 3:** If error is e_n and rate is r_p , then output is o_z .
- Rule 4:** If error is e_n and rate is r_n , then output is o_n .

Therefore, the defuzzification focuses upon the gravitational center in getting the crisp value of μ , which the fuzzy input system requires to drive the fuzzy system. The case study used output membership functions zero, positive, and negative in determining the axis of the graph for linguistic variables [16].

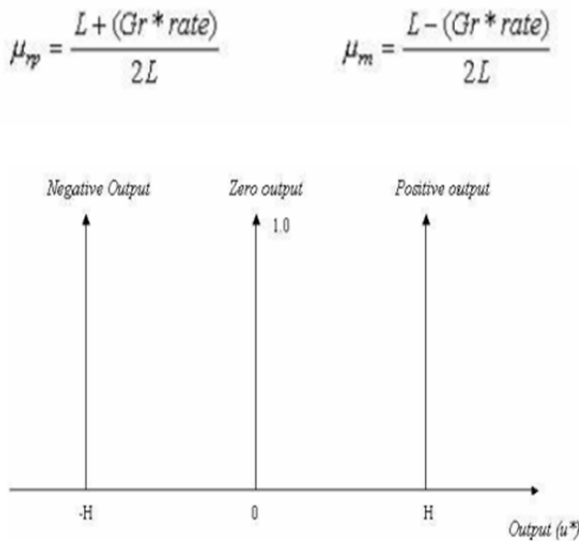

Fig 10: Membership Function Graph

μ represents the membership function that cannot be represented on a graph, but through formulae's such as

$$\mu = \frac{-H(\mu_{R4(x)}) + 0(\mu_{R2(x)+\mu_{R3(x)}) + H(\mu_{R1(x)})}{\mu_{R4(x)} + (\mu_{R2(x)+\mu_{R3(x)}) + \mu_{R1(x)}} \quad (6)$$

This gives a total of twenty possible input conditions through the application of rule 1 though to rule 4. This implies that through the evaluation of the fuzzy rules, defuzzification formulae, and the parameters of the axis provides 9 equations that drives the fuzzification process. Matlab's Simulink is applied in implementing the fuzzy system once the design is complete [16].

The membership functions are defined by the fuzzification inputs that are represented graphically as trapezoidal. A convoluted defuzzification process is exposed, which makes it difficult to mine or pull out the essence. The defuzzification methodology applied is primarily the center of gravity technique, which mirrors the shape and location of the fuzzy sets in a concurrent manner. This case study therefore, demonstrates the fuzzy proportional derivative inference system implementation through Matlab in a Simulink simulation situation. Therefore, the fuzzy system enables users to get graphical interface that makes it possible to draw the schematic processes of running the simulations [16].

Essentially, the design of the fuzzy logic toolkit works seamlessly together with Simulink, where the fuzzy input system is designed using a fuzzy logic set that is directly linked to the Simulink program. Therefore, the fuzzy proportional derivative is very useful for error correction and detection, and is very valuable to experiments concerning multiple sessions that have errors accumulating very fast [16].

(5) **Case Study 2: Motion Tracking and prediction**

The fuzzy system for planar motion tracking and prediction uses a bright colored object against a dark background. The case study describes image acquisition together with corresponding processing steps before fuzzification is undertaken. Therefore, fuzzy logic uses the following hardware for motion tracking and prediction: Toy vehicle, banding filter frequency, USB webcam, and a Pentium 4, as well as the corresponding software being Creative Webcam Pro, Labview 7.1, Ni-IMAQ Vision 7.1, NI-USB, PID Control Toolset [22].

The case study considers exploration of image acquisition and its corresponding processes, while critically examining the application of fuzzy algorithms. The tracking algorithm consists of three major components namely image acquisition, processing, and analysis as described by the following flow chart.

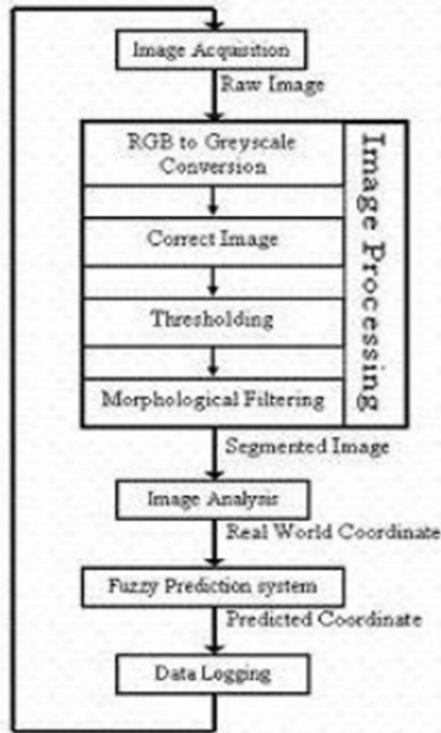

Fig 11: Motion Tracking and Prediction

The image acquisition component of the system is accomplished using a USB webcam, which consistently and continuously gathers images using the highest frame rates. Image processing on the other hand comprises of four sub-components that works on the collected images. The first part focuses on converting the collected images from RGB to grayscale, while the second part corrects the spatial distortion found on the grayscale images. Part three of the image processing is concerned with thresholding, in which pixels below a certain limit are set to zero, or otherwise set to one, and hence the forth part deals with morphological filtering in order to filter out noise through the process of image erosion [22]. The structuring element used is a 3 by 3 matrix consisting of 1's and 0's, and is translated in all rows making up the target image, a single pixel each time. Therefore, the structuring matrix provides a decision point whether a particular pixel is low energy by taking an examination of the neighbors. In cases where a particular pixel neighbors are high, then that pixel is considered to be high energy, and therefore assigned the bit value 1, or otherwise assigned the bit value 0 [22].

Image analysis component applies the real world coordinates of the assigned objects, and is calculated using the center mass of filtered images comprising of two cascaded fuzzy logic controllers. This means that image analysis process is divided into two parts namely coarse motion prediction and fine motion prediction, and each part has its own fuzzification system. However, both fuzzification systems are 'Mamdani' type, and apply equated located triangular membership functions, as well as weighted rule bases, and the fuzzy inference method being Min-Max [22].

When executing the tracking algorithm, a data log is created where data is stored in a temporary array before

being written in a text file once the tracking algorithm has been executed. Throughout the process of the tracking algorithm, the x and y coordinates found in the real world of the objects, the predicted coordinates, as well as the timing of very frame are all logged for purposes of evaluating the fuzzy system performance [22].

The setup of the case study provides useful insights into the application of bright objects against darker backgrounds, as well as the use of cheaper USB webcams. The fuzzy logic systems allows for a wider choice of software, such as the Matlab fuzzy logic toolkit that enables users to easily customize the fuzzy inference system. The software acts as a graphical tool that is designed for both programmers and non programmers [22].

The case study computes the location of objects using center of mass of each object, which also enables tracking of multiple of objects using complex identification patterns. The weighted averages calculated from the fuzzy logic system helps in determining both the identity and the direction the object is facing, which makes the design of the process simple since it is divided down into manageable components [22].

Case study 3: Fuzzy Control in Aviation Technology

Fuzzy control algorithm is appropriate for linear and non linear operations alike, and the case study considers a rough fuzzy controller found in in-house applications. The model Predictive Controller (MPC) processes applies mathematical models in determining the actions the next controller should perform using linear processes, known as a PID controller that is easily implementable. The aviation control areas and variables include velocity, takeoff and landing, turbulence correction, external aerodynamics, yaw or impulse correction, and ABS [26].

The difficulties found in the system include aircraft dynamics that are non linear, uncertain, as well as time varying. Specific aircraft flight condition fuzzy control algorithm are linearized resulting into several algorithms serving specific purposes, while aerodynamically effects on aviation aircraft are difficult to estimate and model since variable such as turbulence fluctuates in unpredictable manner. Safety is of great concern and very important for aircraft within the airspaces, and therefore an effective control algorithm is required in order to ensure safety. This means that the fuzzy logic controller must be thoroughly tested before being implemented [26].

The case study considers several phases of aircraft flight as managed by air traffic controllers sending information to pilots from the ground. In vast air traffic, artificial neural network method is applied in intelligent decision making system working in parallel with the air traffic controllers, and more specifically controlling velocity at both take off and landing [26].

The velocity reduction and increase should be smooth and gradual, as well as should not go beyond the specific aircraft's physical limits. Therefore, pertinent aircraft velocity variable include section length, section velocity limits, and aircraft velocity limits, which are fuzzified into the corresponding linguistic terms combined into appropriate sets of fuzzy rules [26].

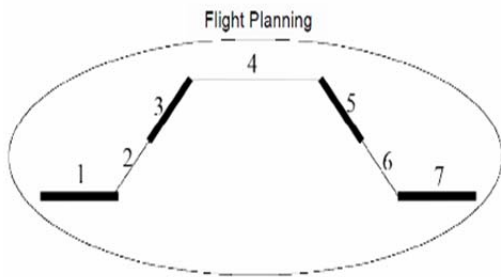

- 1,7 – Taxiing (ground)
- 2,6 – Takeoff /Final approximation
- 3,5 – Terminal area output/ Approximation
- 4 – Navigation

Fig 12: Fuzzy Control in Aviation Technology

Velocity standards at Guarulhos' airport in Sao Paulo, Brazil

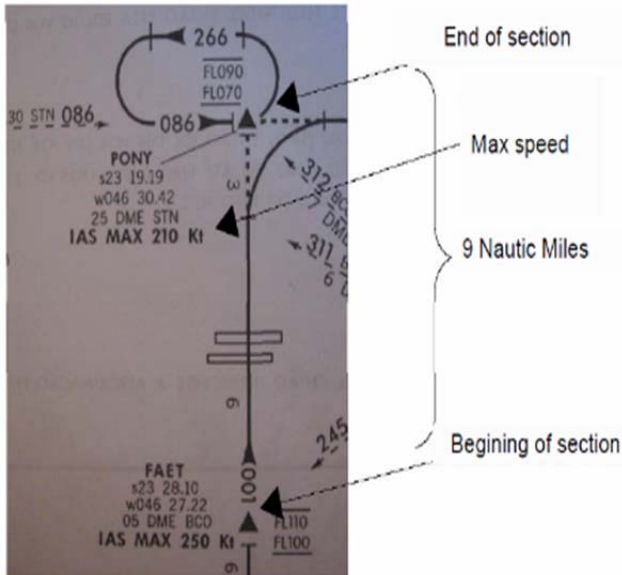

- Linguistic terms (input variables):
- DS - Distance in the section
VS (very small) | SM (small) | ME (mean) | BI (big) | VB (very big)
 - VSEC - Velocity section
 - AV - Airplane velocity
VL (very low) | L (low) | M (mean) | H (high) | VH (very high)
- Linguistic terms (output variables)
- AVR (airplane velocity rate)
MT (keep the velocity)
IN1 to IN4 (different degrees of increase rate)
IN2 to IN4 (different degrees of reduction rate)

Fig 13: Velocity Standards at Guarulho's Airport in Sao Paulo, Brazil

The interviews with specialists revealed the fuzzy decision making considered the following set of fuzzy rules and membership functions.

Membership functions

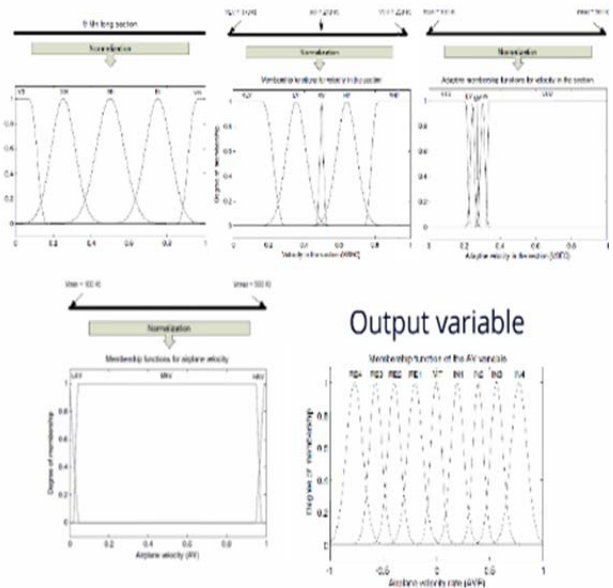
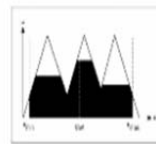

Fig 14: Membership Function Output Variables

Fuzzy rules

- Uses the Mamdani direct method
- Center of area defuzzification
- TX (a new velocity rate) is calculated to maintain the output signal with the boundaries of the aircraft.



$$TX = \frac{\mu(DS, VSEC, AV)}{(V_{max} - V_{min})}$$

Mamdani:
http://www.dma.fisipom.es/tao/fuzzy/fuzzyinf/mamdani_en.htm

Center of area:
http://www.ni.com/reference/en-xx/help/272441G01/ispid/defuzzification_method01/

LAV					
	VLV	LV	MV	HV	VHV
VS	IN3	IN2	IN1	IN1	IN1
SM	IN2	IN2	IN1	IN1	IN1
ME	IN2	IN1	IN1	IN1	IN1
BI	IN1	IN1	IN1	IN1	IN1
VB	IN1	IN1	IN1	IN1	IN1

MAV					
	VLV	LV	MV	HV	VHV
VS	IN4	IN3	MT	RE3	RE4
SM	IN3	IN2	MT	RE3	RE4
ME	IN2	IN2	MT	RE2	RE3
BI	IN1	IN2	MT	RE2	RE3
VB	IN1	IN1	MT	RE1	RE2

HAV					
	VLV	LV	MV	HV	VHV
VS	MT	MT	MT	RE3	RE4
SM	MT	MT	MT	RE3	RE4
ME	MT	MT	MT	RE2	RE3
BI	MT	MT	MT	RE2	RE3
VB	MT	MT	MT	RE1	RE2

Fig 15: Fuzzy Rules

The results of the fuzzy decision making using the set of fuzzy rules and membership functions from the simulation were minimum and maximum velocities the airplane may attain, such as a maximum of 800 kt, and a minimum of 80 kt. The maximum allowable velocities at entrance is 250kt, and at the end is 210 kt, while starting velocities varied between 150 kt and 290 kt. Gradual smoother results obtained for varying membership functions using the Gaussian initially to Bell functions in providing optimization performance measurements [26]. Therefore, the fuzzy logic system displayed an inherent ability to cope with imprecision and uncertainties.

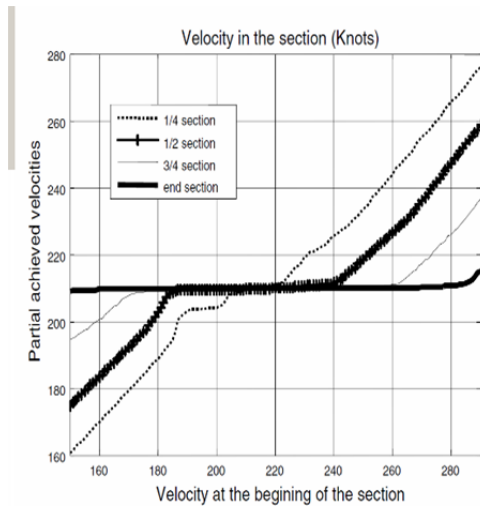

Fig 16: Fuzzy velocity Function

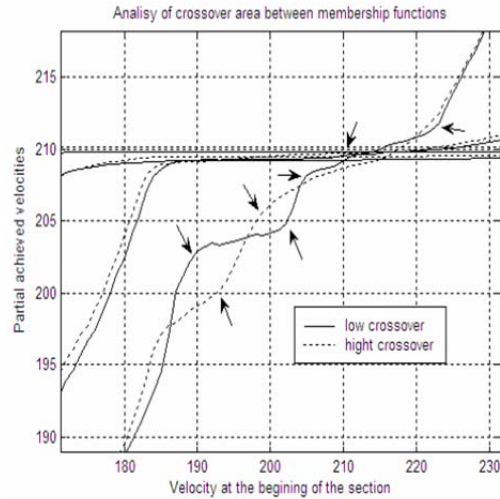

Fig 17: Membership Functions crossover Analysis

Case Study 4: Small Engine Control

The case study describes the development of a fuzzy control system that is cost effective in controlling the aircraft's small engine fuel injector drive pulse width (FPW). The fuzzy inference system uses the engine control unit in getting information concerning the non linear behavior of the aircraft's engine. The fuzzy inference system applies parameters intuitively to the user making tuning and calibration easier [21]. The case study

demonstrates the required tuning in order to obtain the desired levels of emissions, efficiency, and power of the engine, and therefore the fuzzy inference system is able to maintain an optimal air to fuel ratio (AFR) averaging 0.9. The fuzzy inference system applies the manifold air pressure (MAP) and maximum power as input values, and hence produces crisp output values for the fuel pulse width [21].

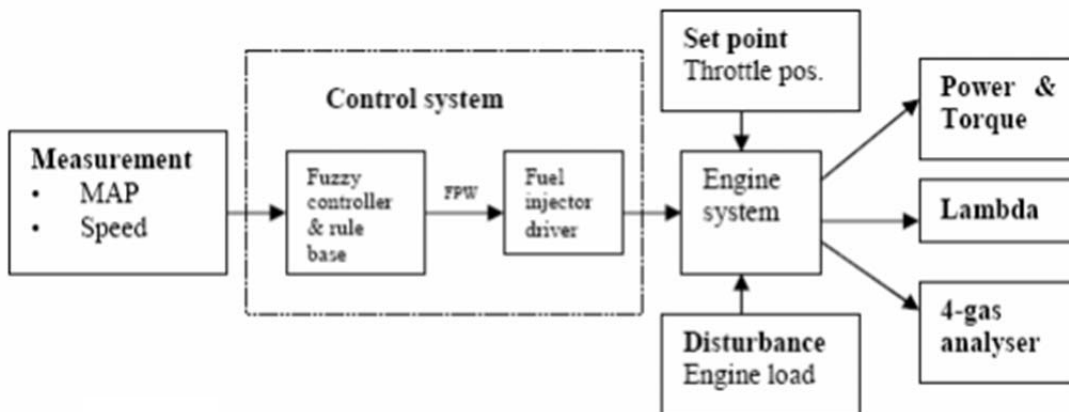

Fig. 1. Block diagram for feedforward fuzzy logic control scheme.

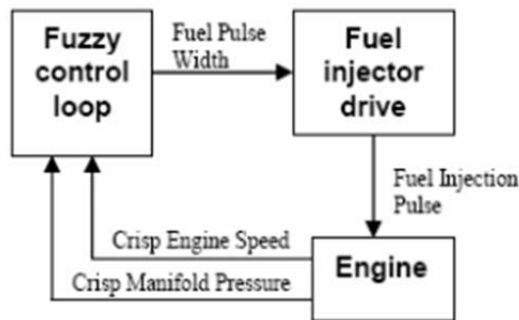

Fig 18: Fuzzy logic Control Scheme

The hardware components include an optical sensor working to determine the aircraft’s engine speed, Horiba lambda Checker (HLC) applied in monitoring the air to fuel ratio, and a pressure sensor working in taking measurements for the manifold air pressure. The software components on the other hand, include windows based operating system consisting of fuzzy rule editor and fuzzy set editor, and fuzzy development environment. Parameters sourced from the fuzzy development environment are transferred to the C++ programmed fuzzy inference kernel module, which is then compiled to a object format in order to be embedded within the engine control unit [21].

The fuzzification process transforms the input linguistic variables having linguistic values corresponding to the membership functions. Therefore, linguistic variables such as speed and vacuum possess linguistic values such as low, medium, and high, which composes at least three trapezoidal functions that display the degrees of membership of input values to a specific linguistic value. This implies that input membership functions can be altered in very process of calibration [21].

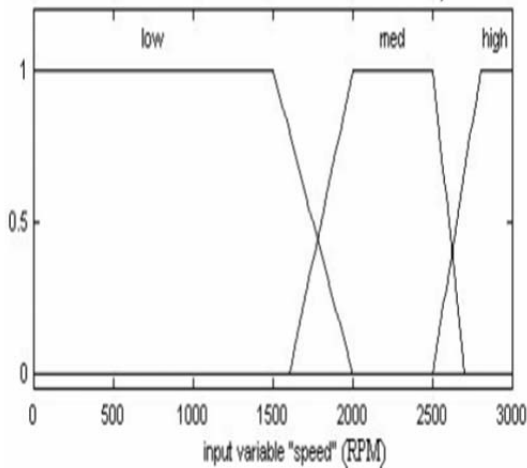

Fig 19: Fuzzy Input Linguistic variable

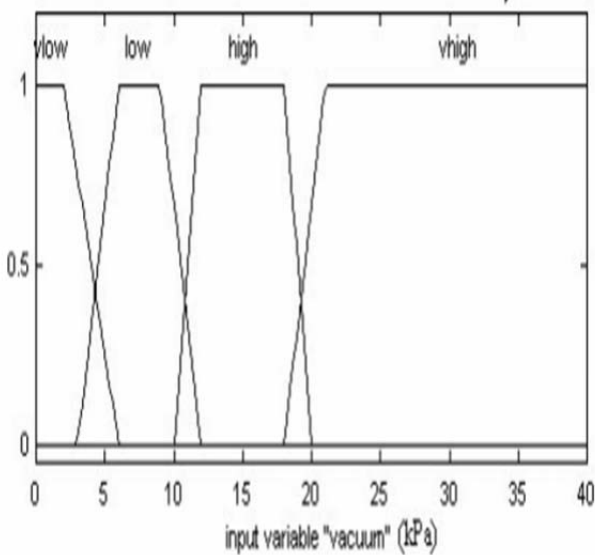

Fig 20: Fuzzy Input Linguistic variable

The fuzzy rule base is defined by

Rule 1:	If the speed is low and the vacuum is very high then fuel pulse width is very small
Rule 2:	If the speed is medium and the vacuum is very high then fuel pulse width is very small
Rule 3:	If the speed is high and the vacuum is very high then fuel pulse width is very small
Rule 4:	If the speed is low and the vacuum is high then fuel pulse width is very small
Rule 5:	If the speed is medium and the vacuum is high then fuel pulse width is small
Rule 6:	If the speed is high and the vacuum is high then fuel pulse width is small
Rule 7:	If the speed is low and the vacuum is low then fuel pulse width is small
Rule 8:	If the speed is low and the vacuum is very low then fuel pulse width is small
Rule 9:	If the speed is medium and the vacuum is low then fuel pulse width is large
Rule 10:	If the speed is medium and the vacuum is very low then fuel pulse width is very large
Rule 11:	If the speed is high and the vacuum low then fuel pulse width is very large
Rule 12:	If the speed is high and the vacuum is very low then fuel pulse width is very large

Fig 21: Fuzzy Rule base

A singleton defuzzification output membership function is applied for the valid ranges of output values, especially when these values are discontinuous. However, straight lines represents these function in four possible output options, with a combination of a varied degrees of membership in producing outputs such as 142, 143, 143.3, 143.4, and 144.

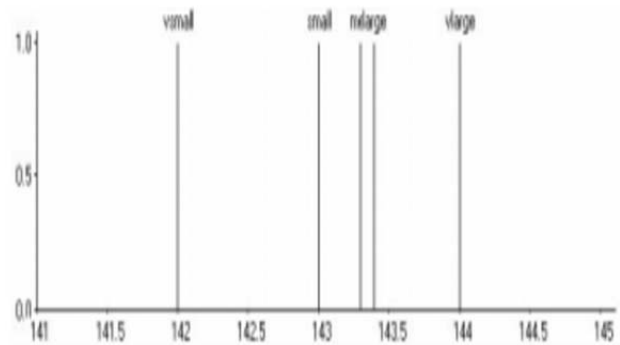

Fig 22: Defuzzification Output Membership Function

The membership functions in this fuzzification case study considers trapezoidal shaped input values, and ensures that only a single value attains the highest degree of affinity a the fuzzy sets. This implies that degrees of affinity of the membership functions are assigned between zero and one. The fuzzy inference system determines the orientation of the object in terms of its density and patterns by using a ranking system [21].The three derived membership functions referred to as high rank, medium rank, and low rank, and given that the highest rank is assigned 1 and lowest rank assigned 0, imply that the strength of the fuzzy inference system emanates from its capacity in error tolerance. The Bell shaped or trapezoidal shaped membership functions are of Sugeno type used in linear systems having consistent outputs [21].

Case study 5: Air Engine Diagnosis

Collecting sensor data is essential in remotely monitoring the engine during several flight regimes, which is ultimately transmitted to ground based system for fault diagnosis and anomaly detection. Therefore, timely and prompt accurate diagnosis is pertinent to problem

resolution, and fuzzy computing models provides leverages in using engineering knowledge to accurately capture engine failure root cause analysis. The fuzzy inference system in the case study captures multi parameter movements from flight snapshot data that are mapped against the fuzzy rule set related to the engineering knowledge of the patterns of failure signatures [25].

Shift detection measures and detects outliers, parameter shifts, as well as correlates parameter shifts in order to decide on a specific event start time, while the fuzzy knowledge model represents the engineering expertise concerning failure root cause and its corresponding symptoms. Fuzzy T integration is concerned with the probability of having a match between an anomaly for a specific pattern and engine sensor shift in getting the required fuzzy score rule for the three parameters defined. Hence, the result scores for each fuzzy rule gives the root cause that has the highest score of 0.726 having failure cause 18 [25].

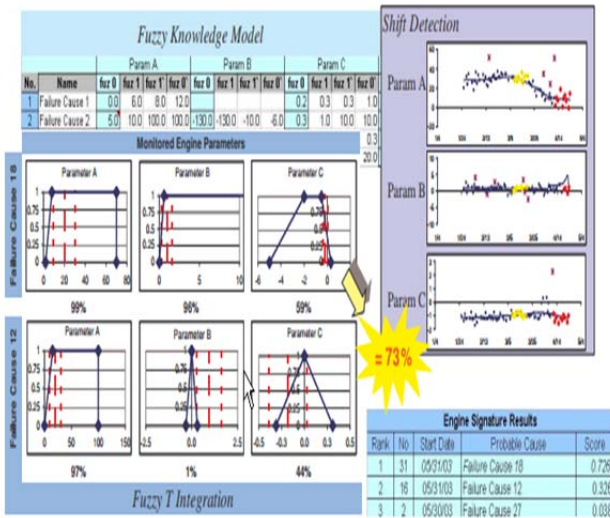

Fig 23: Fuzzy Knowledge Model

Therefore, the fuzzy knowledge model is created offline using engineering knowledge and leveraging historical diagnostic experience. When online, engine flight operation data is processed for pattern and trend analysis, as well as shift detection for which the diagnostic result captures the variance of the fuzzy rule engine. The non calculus genetic algorithm approach applies natural selection for the search algorithm, as well as evolutionary theorems in choosing the optimal performance for multi generation of possible solutions [25].

The genetic algorithm learning technique successfully uses fuzzy model tuning thus enabling quick convergence to almost optimal state using huge search space having a minimal set of operations. The root cause analyzer diagnostic process is optimized through fuzzy knowledge module and data analysis module, which collects engineering knowledge for failure signatures [25].

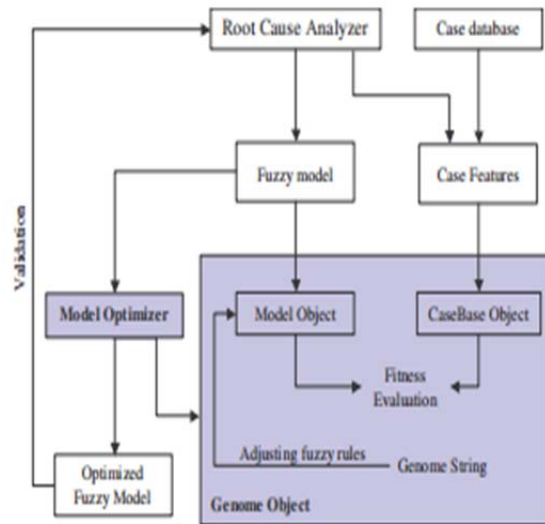

Fig 24: Fuzzy Root Cause Analyzer Model

The goals of the case database is to optimize the maximum accuracy for the diagnostic model by using the historical cases set, and therefore the case base collects and records negative and positive events, which are used for validation and model tuning. Therefore, positive events are useful for known engine anomalies cases of specified types, while negative events represents events or engine cases that have unknown anomalies, and hence represents events that helps in adjusting normal engine behaviors and fault detection sensitivities [25].

The model optimizer initiates, controls, and configures the genetic algorithm tuning process by using a set of constraints, which are set up for a viable range of tunable fuzzy variable. The module further specifies the genetic algorithm parameters that control the reproduction process and the population alike. Adjustable quick convergence at the localized maxima is needed for maintaining candidate diversity, and large population's sizes. The reproduction control parameters such as mutation rate, crossover rate, and replace rate are set by the fuzzy inference system so that the output is optimized by adjusting the parameters [25].

The diagnostic model structure is unchanged during the tuning process in order to decrease the complexity problem, and also to provide maintenance to the engineering knowledge. However, learning is restricted to the existing fuzzy rules thus limiting generation of new terms related to experience data. Therefore, the limitation is encountered by gathering signatures for the unknown failure modes, which also uses the cost functions within the fuzzy model optimization process [25].

Case Study 6: Fly by Wire

Fuzzy logic fly by wire uses control systems that can be implemented in a variety of aircraft, such as military F-16 fighter, and other commercial aircraft such as Boeing 777 and Airbus A320. The control inputs for fly by wire fuzzy logic from the pilot are transmitted electronically through wires to the hydraulic servo surfaces. Inputs from the pilot are processed with other flight data displayed on-board

computers, thus [providing the flight maneuver desired [28].

Fuzzy logic fly by wire essentially refers to added safety through programming routines that helps in the prevention of stalls, uncontrolled flight, and over speeds, as well as other features that compensates for engine failure and enhanced stability in adverse weather conditions automatically to extremely low probabilities [28]. The fuzzy logic control air vehicle uses genetic algorithms in aircraft control applications, such as provided by Sugeno for controlling unmanned helicopters. Sugeno fuzzy inference systems apply techniques and knowledge of experienced pilots, and hence the on-board fuzzy logic controller is implemented in order to attain intelligent control, which can also be tele-controlled using verbal commands from the ground [28]. Therefore, the autonomous fuzzy control performs and stabilizes the helicopter for maneuvers such as landings.

The Jetliner that was modified by NASA to imitate the Shuttle Spacecraft's response applied the fuzzy flight control fly by wire system, where pilots inputs were transmitted to fuzzy logic processor in order to settle on control surface deflections assimilate the space Shuttle. Matlab and Simulink were used to develop the flying robot, where flight characteristics are modified the simulator program, hence giving a close equivalent to the actual RC model. The case study continued to refine the membership functions and fuzzy rules throughout the project life cycle, with keen emphasis being placed on the importance of coupling in relation to the rotational axis and translational axis [28].

The case study addresses the issue of coupling for very extreme circumstances, such as the effect of adverse yaw in a turn, and therefore compensation is enhanced by prevention of uncontrolled flight conditions. This means that yaw rate sensor data for gyro is transmitted to the roll controller and the yaw controller, which consequently gives users help in stability maintenance even in cases of secondary coupling effects [28]. An altimeter is added in order to provide take off and landing data, and is used to prevent the aircraft from wandering out of range. The accuracy of the fuzzy inference system for the fly by wire stands at ± 5 meters, which is adequate but not good enough. A global positioning application system is applied by the Sugeno to make the fuzzy inference system more accurate, as well as help in not exceeding budgetary factors. Therefore, the case study concluded that it is important to consolidate hardware boards and membership functions in order to have a more compact and portable efficient unit [28].

IV. RESULTS AND ANALYSIS

A. Account For Fuzzy Systems and Applications Evolutionary Genetic Algorithms

Learning from previous research and insights provided by the case studies, it is clear that different paths can be taken into the design and implementation of fuzzy inference systems for the aviation industry. Research literature and the case studies reveal several membership function shapes such as triangular, trapezoidal, and Gaussian with a wide

range of appropriate degrees of affinity. It is important to note that triangular and Gaussian shapes are appropriate if only a single maximum degree of affinity is required, while trapezoidal or bell shaped membership function can be replaced by any other function provided it plateaus. Different rule bases are used for specific problem situation in the development of fuzzy controllers in consideration with the linguistic variables, so that the inputs are fuzzified in order to obtain the most optimal output [19].

Making a choice between Sugeno and Mamdani type fuzzy inference systems depends upon the type of inputs, and it appears that Sugeno fuzzy inference types are best suited for linear inputs, while Mamadani works well with human inputs that are intuitive. It is apparent that the Sugeno fuzzy inference systems comes as superior in terms of computational efficient systems that applies adaptive models, as well as being compact that lends more constraints on the fuzzy inference system [18].

The present state of research does not emphasize direct control of aviation aircraft but only pursues to help the pilots by provision of advice and monitoring capabilities. Therefore, there is not much to be leant concerning fuzzy rule base drafting, given that the appearance of bright objects against dark backgrounds is modeled through the knowledge of the real world system depending on the degrees of distortion and orientations. Therefore, in most cases the fuzzy inference system architecture selected applies the encoded knowledge, and hence acts as an assisting pilot using expert rule systems and fuzzy logic in relation to navigation, safety, and all aircraft performance issues [14].

The overlap that occurs between modes mirrors the uncertainty levels that exists in defining aircraft flight modes and transitions from one mode to another is gradual rather than discrete. There are numerous sources of uncertainty and includes the differences in different pilots flying techniques over varying flight conditions from one day to another. Therefore, the uncertainties present actually prompts and motivate the development of fuzzy solutions for the optimization of flight problem in terms of mode interpretation. However, discrete and crisp limits or boundaries cannot be specifically drawn between different flight modes [32].

Fuzzy inference systems are fundamentally valuable for engineering and provide a means of encoding human knowledge and transforming it into expert systems. This implies that fuzzy logic provides automation of human decision processes using decision rules that can be referenced in terms of IF/THEN fuzzy base rules. Therefore, fuzzy logic is important for allowing uncertainty to be present in decision making processes. However, past fuzzy logic control applications were successful for fuzzy inference systems that had relatively lesser measured states and control rules, while recent rush forward of fuzzy logic applications have the same amount of strength, as well as revealed a number of limitations and weaknesses [29].

One major limitation of the present fuzzy inference systems is the complexity of interpretability of multivariate flight modes, and therefore multidimensional fuzzy membership functions enables a method of partitioning multivariate

state spaces into fuzzy component regions. It is apparent that complex aviation decision and control problems having several inputs will require enormous rule bases for the fuzzy systems, and therefore rule bases increases exponentially in relation to the amount of required inputs. Large fuzzy rule bases on the other hand, appear to be difficult to encode and very complex to validate [36].

It is also very important to note that by shifting from one dimensional fuzzy inference system to multidimensional fuzzy inference systems drastically reduces the number of rules required, which essentially reduces the degree of complexity. Another essential limitation of the present state of the art fuzzy inference systems in aviation industry is the inconsistent and cumbersome nature of correlating between the input variables in the fuzzy models, for instance in terms of interpretability of flight modes finds a correlation existing between the input variables in the definition of the flight modes, and therefore it is important to note that multidimensional fuzzy membership functions effectively addresses the issues of fuzzy rule base sizes and correlation [36].

B. Interpretability Accuracy

The impact of the fuzzy rule base sizes on generated fuzzy inference systems in aviation technology in terms of predictive accuracy are modeled in order to develop effort and detect proneness, as well as estimated product size. It is imperative that Fuzzy Systems and Applications Evolutionary Genetic algorithms in the Aviation Industry are specifically designed to manage uncertainty well, and therefore aviation industry managers need excellent understanding concerning the nature of risks. This implies that identification of risks that may adversely affect a flight in terms of quality, safety, budget, and other aircraft control factors must be determined in setting priorities for the fuzzy models [11].

Flight conditions must prioritize the risk factors that can enhance reliability of success are identified and arranged in a hierarchical nature, which must be founded on knowledge obtained from an adaptive fuzzy inference system that is designed to evaluate such risks. Fuzzy inference systems models for the aviation industry display more satisfactory appraisal of aviation aircraft safety and control risks.

The systematic assessment and evaluation of the effect of aviation safety parameters, and analysis of empirical outcomes of the Fuzzy Systems and Applications Evolutionary Genetic algorithms in the Aviation Industry must consider the effect of the rule set size, membership function shapes, and the fuzzification process [11]. However, a trade off must be made in having smaller rule base against the degree of predictive accuracy of the decisions made with respect to obtaining the optimal solution. The empirical findings reveal that the aspects of rule set membership functions influences the sensitivity of the implemented fuzzy inference system, as well as the impact of analysis of outcomes [11].

The superior performance of fuzzy inference systems appears to be based on a combination of artificial intelligence methods, and therefore the path which fuzzy inputs convey the sample coordinates of input membership

functions changes as it goes through the available rules. Therefore, the category of the fuzzy inputs is determined by the value of the fuzzy rules set for the out characteristics. It is imperative that the output membership functions are mapped to a single valued output which refers to the decision associated with the desired output. From the foregoing, Gaussian and Bell shaped uses rules based on the fuzzy logic model and linguistic variables that depends on error methods and user experience [16]. Additionally, the shape of the membership functions has a significant effect on the parameters, and therefore altering these parameters changes the shape of the membership functions. Therefore, the limitations of Fuzzy Systems and Applications Evolutionary Genetic algorithms in the Aviation Industry are evident in neural fuzzy applications since they are chosen through trial and error method, as well as being dependent upon the user experience [21].

The most advantages of the Fuzzy Systems and Applications Evolutionary Genetic algorithms in the Aviation Industry are their ability in learning, as well as its power in performing high numerical computations. This implies that flight safety concerns associated with the determination of the location and shape of the membership functions for each fuzzy variable included with the fuzzy inference systems, optimization efficiency depends on the premise of the estimated parameters and their consequent components, and therefore factors such as learning rates are important for solving problems associated with trial and error methods [21].

C. Multiobjective Based Fuzzy Systems for Multidimensional Learning Data Problems

Multiobjective based fuzzy inference systems generates interpretable fuzzy models using experimental data, and are therefore desirable for human users in understanding complex systems. The accuracy and interpretability tradeoffs between fuzzy rule set classifiers are implemented in the framework of evolutionary multiobjective, where each fuzzy rule is an antecedent of fuzzy sets represented as an integer string comprising of a fixed length [27]. Therefore, fuzzy rule based classifiers are modeled as concatenated integer strings having varying lengths. Therefore, Multiobjective Based Fuzzy Systems for Multidimensional Learning Data Problems at the same time minimizes complexity of fuzzy rule sets, while maximizing their accuracy. Given that complexity refers to the number of antecedent conditions of fuzzy rule sets, and the, while accuracy is measured in terms of the number of correctly classified patterns of training, implies that the accuracy and interpretability trade off for every learning pattern applies computational experiments in setting benchmarks for the data sets [27].

Optimal tradeoff structure is implemented and visualized for every data set, and therefore examines and evaluates the accuracy and interpretability trade off using the test patterns. The multiobjective evolutionary algorithm that is driven by Mamdani fuzzy rule based set systems have varied alternative tradeoffs between accuracy and complexity. However, the fuzzy inference system is driven by an algorithm that is not only rule based, but also

granularity is present in uniform partitions that are defined by the concurrently learned input and output variables [34]. Multiobjective Based Fuzzy Systems for Multidimensional Learning Data Problems codifies partition granularity variables and virtual rule bas, where genetic operators manage these virtual bases. This implies that evaluation of fitness primarily depend on an efficient mapping strategy between concrete rule bases and virtual rule bases, especially for regression problems [34]. The main advantage of the fuzzy rule based design evolutionary multiobjective systems over non linear models lies in the neural networks, which have high degrees of interpretability in a linguistic approach. Interpretable Multiobjective Based Fuzzy Systems for Multidimensional Learning Data Problems are very desirable for pilots and other aviation industry personnel, since they are driven by optimization tools that generate fuzzy rule based systems that have varied trade offs for accuracy and interpretability. This is possible because the computational cost and search space size of fitness evaluation relies on the instances and number of input variables [34].

The applications for learning concurrently the rule bases that are Mamdani database driven fuzzy rule based systems tackles the problem of exploitation of the synergy found between at least more than two competing techniques. However, initial technique would be based on reducing search space through learning rule bases from heuristically generated fuzzy rule base [32].The succeeding techniques would involve carries out instance selection through the exploitation of the co-evolutionary approach that cyclically evolves the genetic algorithm to reduce the learning set. Therefore, Multiobjective Based Fuzzy Systems for Multidimensional Learning Data Problems generates fuzzy rule systems, exploits more than one technique, and copes with large regression and high dimensional data sets aimed at fitness evaluation time and the reduction of the search space [32].

Genetic Fuzzy Rule-Based Systems:

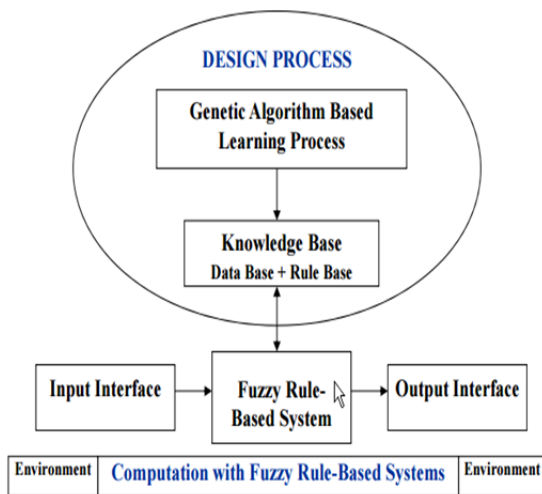

Fig 25: Genetic Fuzzy Rule Based systems

D. Problems in the Hybridization between Genetic Algorithms and Fuzzy Logic

There are two common methods of integrating genetic and fuzzy logic algorithms, where the first instance involves applying fuzzy logic based approaches for modeling adapting genetic controller parameters and a number of varied genetic algorithm elements with the aim of enhancing performance. The second instance involves the use of search problems concerning fuzzy systems and applying genetic algorithms for optimization problem solving. In essence genetic algorithms make possible the hybridization of local search methodologies in obtaining the optimal solution, and therefore genetic algorithm and local search are two complementing solutions [37].

Genetic algorithms work well with finding global searches with the capability of finding promising regions faster, however are quite slow in finding the optimal solution in these regions. Local search on the other hand find local optimal solution faster with high level of accuracy but is limited with the problems of foot hills. Therefore, a perfect intermingling of genetic algorithm having local search capabilities aids in exploiting optimization and search algorithms. It is obvious that the performance of genetic algorithm relies with the methods of balancing the conflicting objectives of exploitation and exploration, where exploitation refers to exploiting the available best solutions and exploration refers to the search space for other promising solutions [36].

The complimentary view of the hybrid genetic algorithms involving local search and genetic algorithm methods are used for capability enhancement and optimization of the control parameters. There are several ways of optimizing the by and large local search methods in combination with genetic algorithm, which improves performance by enabling feasible solutions production with highly constrained problems [36].

A number of issues and problems arise with the Hybridization between Genetic Algorithms and Fuzzy Logic. One of the major issues with hybridization involves the adaption of genetic algorithm control parameters, given those fuzzy logic controllers when applied dynamically with the use of knowledge and experience induces suitable exploration and exploitation relationship throughout the execution of the fuzzy inference system, but introduces the problem of premature convergence. The other major issue involves crossover operators, where triangular probability distributions and fuzzy connectives are considered in the design of powerful crossover operators establishes sufficient population diversity levels, and therefore makes the fuzzy inference system vulnerable to attacks of premature convergence [28].

The problem of classical binary representation that uses the genes 0 and 1 are generalized fuzzy genes, and therefore it is better to have more complex genotypes as opposed to phenotype relationships found in real life. Uncertainty and belief measures introduces the problem of stopping criteria, which must be taken into account when handling predictive solutions to enable enforcement of the genetic algorithm in finding optimal solutions using user defined accuracy. Because of the likelihood of premature convergence,

genetic algorithms do not warrant the finding of an optimal solution [39].

The problem of balancing between local and global search for optimization problem can be dealt with applying a mutating operator that improves the exploring ability for genetic algorithm by directing the search to the highest promising regions within the search space. Therefore, the aim of hybridization is satisfied by the cooperation between the local search and genetic algorithm. However, crossover and mutation operators may distort good thus wasting algorithm resources hence the production of inefficient search. Furthermore, the improper application of hybrid algorithm using expensive local search leads to waste of algorithm resources [39].

It is apparent that local search and learning apply local knowledge in enhancing the likelihood of an individual to be promulgated into the preceding generation, and therefore the local search is perceived as a learning process. This implies that the gained knowledge and its applications have enormous effect in improving the algorithm performance; however, this method forces the genetic structure to mirror the outcome of the local search. However, this never occurs in many fuzzy inference systems because of lack of mechanisms of accomplishing it [39].

The aim of hybridization should be making search effective if the two algorithms can work in combination by cooperating their resources, otherwise the result can be very destructive. Therefore, for an effective search both methods must interact cooperatively, and methods of minimizing the improper application of the hybrid scheme include using local search parameters in terms of period of local search, selection and likelihood of local search, and local search frequency [39].

of fuzzy logic systems; however they can be overcome by wholly integrating soft computing paradigms into evolutionary neural fuzzy systems. Adaptive neuro fuzzy systems that can learn from available data are constructed from fuzzy inference systems that are multi layered in the neural architecture [8].

Soft computing paradigms of fuzzy systems with the use of evolutionary algorithms with learning data and adaptive capabilities comprises of the adaptation process, and the intelligence component. The adaptation process of artificial neural networks consists of making adjustments to the conditions in the environment, such as a change in the linguistic variables like temperature means a change to the quality or intensity of simulation. The systems also adapts by modifying some elements of the surrounding environment, specifically those that makes the fuzzy inference system to make more fit for existence under the prevailing environmental conditions [23].

The artificial neural network of the evolutionary computing systems learns and understands, as well as deal with trying and new situations. Therefore the neural networks manipulate and apply knowledge in the environment, as well as think in an abstract manner and are measured with reference to the objective criteria. Adaptive database framework that applies evolutionary algorithms supports decision making systems by delivering fuzzy IF/THEN rules with highly complex computational abilities that leads to enormous amounts of simulation time [23].

The major problems with the artificial neural network of the evolutionary computing systems learn and understand includes the need of expert knowledge in modeling the objective function that sets up the fuzzy rules. The fuzzy inference technique enables approximate human reasoning, and the genetic optimization and neural learning makes the fuzzy inference system to learn the fuzzy logic model using any given data set, which is optimized for interpretability and accuracy [8].

F. Aviation Safety and Risk assessment

Promoting aviation safety operations using fuzzy inference modeling approaches have characteristics such as safety procedures, personnel capabilities, and aircraft performance, which all impacts aviation safety. When dealing with situations with high levels of uncertainty requires strategies that evaluates the factors in the risk base in line with either risk mitigation or reduction, with respect to human factors, weather conditions, aircraft type, aircraft lighting, as well as other surface conditions. Fuzzy inference systems approach performs risk analysis through the provision of the proactive measures in risk reduction during the initial stages of the fuzzy model design [17].

Flight delays and safety is a common problem, and safety management systems built on fuzzy logic models combined with appropriate decision making process demonstrates useful insights into effective Aviation Safety and Risk assessment. The traditional approaches of probabilistic decision making techniques for safety risk analysis have been used, however fuzzy probability estimation uses expert confidence index in ensuring reliability of data. Therefore, defuzzification processes overcomes limitations that lends themselves to fuzzy linear estimations, and

Evolutionary neuro-fuzzy systems and applications

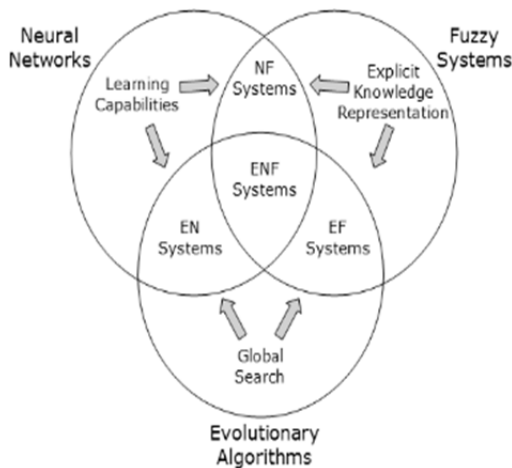

Fig 26: Evolutionary Neuro Fuzzy Model

E. Learning Data and Adaptive Capabilities

Evolutionary neuro fuzzy inference systems and applications hybridize the approximate reasoning with learning capabilities of evolutionary algorithms and neural networks. This hybridization strategy has innate limitations

therefore the fuzzy inference system applies sensitivity analysis in evaluating the proportion of contribution of basic factors of risk events [24].

Fault diagnosis systems based upon fuzzy logic parity equation relying on non linear systems are drawn from entirely decoupled parity equation. This implies that the residuals that are derived from it become only sensitive to the particular sensor or actuator fault. This implies that the fuzzy logic parity equation derive the fuzzification process of the residuals by applying another traditional linear model. Therefore, the digital human in aviation safety is influenced by factors such as coverage, which means the pilot selection range, visibility, comfort, accessibility, cooperation, and decision making [17].

Given that security is a major challenge to the aviation industry means that attacks must be reduced in order to enhance passenger safety. The fuzzy logic system must be flexible, knowledgeable, efficient, and dedicated while making effective judgments that enhances aviation safety. Environment also poses a great challenge to aviation safety, and factors such as aviation weather including lighting, turbulence, wind, and precipitation are variables that the defuzzification engine use intelligence from human error such as communication gaps, pilot's errors, errors in design and repair, and so on. Therefore, the fuzzy inference modeling covers for human error, as well as promote security management including subjective variables such as attitude or level of training, experience of personnel and aviation security systems [24].

V. DISCUSSION

The discussion of the results and corresponding analysis of the research study discusses and quantifies the tangible and intangible benefits of fuzzy environment in relation to optimization of aviation safety, as well as the limitations of fuzzy inference systems in the performance of aviation technologies. The application of the fuzzy sets theory in developing economic evaluations and hierarchical heuristic structural analysis uses Fuzzy Systems and Applications Evolutionary Genetic algorithms in the Aviation Industry. Computer based prototypes for aviation performance models handles complex fuzzy calculations, where decision making systems apply pertinent factors in terms of linguistic variable scales such as very high, medium, and very low being converted to fuzzy numerals [26].

An integrated fuzzy approach is necessary for designing aircraft transportation by applying theory of constraints, fuzzy set theory, and balanced scorecard, which must be integrated in order to satisfy the design process for maximum optimization that meets the needs of customers, shareholders, and employees. Aviation errors occurs in all aspects of the industry including maintenance errors, aviation incidences, and therefore aviation industry wide safety and performance improvement requires progressive innovative tools for preventing and eliminating errors from occurring [26].

Fuzzy logic handles the concept of super set of Boolean or conventional logic and the concept of partial truth, and therefore considers the gamut of fuzzy values from completely true to completely false. While aircraft design

comprises several steps including structural analysis, flight control design, and aerodynamic design, flight control is a very significant component that directly affects aviation safety and [performance. Fuzzy logic enables the aviation industry to depend on automated control systems for functions that demands persistently efficient controllers [26].

As much as conventional controllers work efficiently for systems that follow linear patterns in the real world, aviation dynamics require highly non linear controllers that perfectly work with non linear trajectories. Fuzzy logic controllers applies non linear control methods in terms of linguistic approaches based on specific sets of rules and membership functions in designing controllers functions for autopilot aviation operations. The safety level is a very crucial aspect of the aviation industry, and the grounds examination of the predicted air traffic and airspace challenges, such as increased air traffic increases the safety responsibility. Therefore, hazards and risks recognition and analysis fundamentally defines the safety level of air traffic [38].

Integrated fuzzy approaches based on abstract objects, mapping design attributes, function space theory, air traffic system model, and integrated aviation includes both static and dynamic parameters of aircraft, air traffic control, and airport. The novelty of the integrated fuzzy approaches is based on complexity, integration, and flight specificity attributes. However, the theoretical fuzzy model comprises the meteorological parameters, system infrastructure, system components, and human factors or agents, as well as the entire active system and processes of the loaded. Therefore, the Fuzzy Systems and Applications Evolutionary Genetic algorithms in the Aviation Industry must take into account the complexity of the present loaded parameters [38].

A significant task for aviation industry operators is the establishment of a risk assessment of airports and aircrafts safety through the identification of risk items, and measuring risk value objectively. Therefore, application of fuzzy logic in finding out the significance of decision factors in relation to effect, failure modes, and critical analysis. The decision factors include severity, probability, and detect ability of aviation risks that helps in discovering the threshold of the value of risk. Fuzzy logic provides techniques with respect to linguistic terms that make critical assessment of risk linked to failure modes in a natural manner. The IF/THEN fuzzy rules using expert knowledge formulates appropriate rules for coping with situations in linguistic terms [38].

Obtaining an optimal solution is the primary function of fuzzy models in problems affecting the aviation industry, and fuzzy controllers and fuzzy expert knowledge must have predefined membership functions together with fuzzy inference rules that transform numerical data into linguistic variable factors. Thus the performance of fuzzy reasoning proposes learning methods that provides a framework for the derivation of fuzzy membership functions and IF/THEN rules from a set of fuzzy training examples, thus building prototype fuzzy logic expert systems in a complex environment. In essence, the fuzzy controllers uses fuzzy

rules directly and fuzzy theory in creating fuzzy controlled engine by fuzzification, that is applying membership functions by graphically describing a particular aviation situation. The rule evaluation applies fuzzy rules, which defuzzification then obtains actual or crisp results [27].

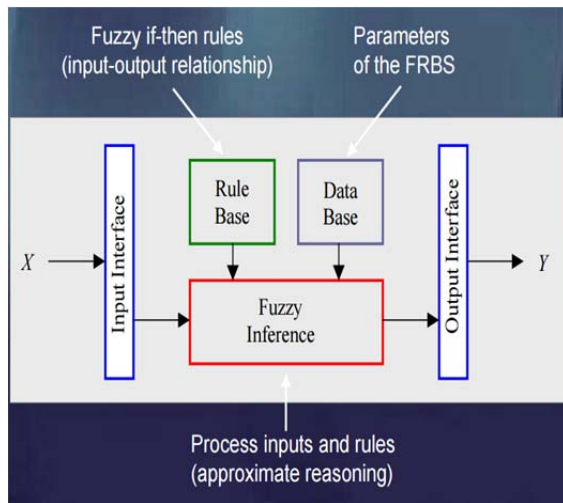

Fig 27: Approximate Reasoning Inputs and Rules Processes

Neuro fuzzy cooperation model prototype development requires learning ability and precision in making the ability of the neural network easy to understand by acquiring knowledge from experts and converting the fuzzy system into neural system [14]. Fuzzy logic in aviation control systems therefore, converts linguistic controls into automated control strategy by constructing a fuzzy logic control system that assesses the performance and problems of fuzzy reasoning implications. Therefore, within the aerospace domain requires optimal solutions for complex search, as well as planning problems, of which genetic algorithms comes very useful. Genetic algorithms provide wide-ranging populations of solutions that enable aviation operations to cope with the changing aerospace circumstances. Genetic algorithms learning of neural model for aviation guidance and control requires complex airframes, which improves performance in stressful maneuvers [14]. Therefore, autopilot's airframe is highly non linear in highly cross coupled environments, and hence guidance and control comprises multiple inputs that generates appropriate outputs within neural net architectures that provides greater robustness.

VI. CONCLUSIONS AND RECOMMENDATIONS

The overall contribution of this research to the Fuzzy Systems and Applications Evolutionary Genetic algorithms in the Aviation Industry evaluates performance and needs of optimization the current fuzzy inference systems. The incorporation of fuzzy logic into neuro adaptive learning with appropriate fuzzy design rules and membership functions significantly improves defuzzification outputs in relation to appropriate fuzzy inputs. The motivation behind the development of multiobjective evolutionary systems has helped to address most of the problems and challenges of the conventional control systems using linear methods. Therefore hybridization and adaptive learning fuzzy

systems have enhanced the dimensionality of fuzzy inference systems in terms of accuracy and interpretability, and hence fuzzy systems in uncertain aviation conditions deals with anomalous inputs that help deal with optimizing the real world challenges into automatic determination.

Based on the literature and empirical case studies, the performance and safety index in the application of fuzzy logic systems views the empirical evidence in a number of perspectives, such as systematical fuzzy inference designs that reflects aviation probability, scientific feasibility that displays aviation profitability, expansibility referring to having ability to be replicated in different regions, periods, weather conditions, and other aviation conditions. Independence is important characteristic of efficient and effective fuzzy inference system by the fact that they are relevant to other fuzzy systems and conventional systems, as well as objectivity where the safety and performance index is measured in terms of the evaluation being made.

Future research should be devoted in real time planning, and therefore developments should consider more research into delays on airports, weather conditions, and other aviation events that compromise safety and performance such as aviation accidents and attacks. Self adaptive neuro fuzzy inference systems with learning capabilities are the direction of future research and innovation in the Fuzzy Systems and Applications Evolutionary Genetic algorithms in the Aviation Industry.

Future developments should consider innovations in designing fuzzy logic controllers for non linear systems that are easier to use as compared to traditional controller designs. This implies that spatiotemporal framework for adaptive network based fuzzy inference systems should greatly improve performance and safety index in terms of structural similarity index that will successfully evaluate generated fuzzy outputs. The human limitations will completely be eradicated with modeling techniques that promote adaptive learning in the field of neural networks, and hence will provide an appropriate balance between numerical accuracy and interpretability of the predictive ability of fuzzy rules and membership functions. Therefore, identification and analysis of threats to safety and performance of aviation systems must carry out probabilistic criteria in using neural networks and fuzzy logic expert inference systems.

REFERENCES

- [1]. R. T. Jones, "Improving the Efficiency of Smaller Transport Aircraft," 14th Congress of the International Council of the Aeronautical Sciences, proceeding, Vol. 1, Toulouse, Fr. 1984.
- [2]. R. T. Whitcomb, "Methods for Reducing Aerodynamic Drag," NASA Conference Publication 2211, Proceedings of Dryden Symposium, Edwards, California, 1981.
- [3]. J. J. Spillman, H.Y. Ratcliffe and A. McVitie, "Flight experiments to evaluate the effect of wing-tip sails on fuel consumption and handling characteristics," *Aeronautical Journal*, pp. 279-281, 1979
- [4]. M. J. Smith, N. Komerath, R. Ames, O. Wong and J. Pearson, "Performance Analysis of a Wing with Multiple Winglets," *AIAA Paper- 2001-2407*, 2001
- [5]. A. Hossain, P. R. Arora, A. Rahman and A. A. Jaafar, "Iqbal, Analysis of Aerodynamic Characteristics of an Aircraft Model with and Without Winglet," *Jordan Journal of Mechanical and Industrial Engineering*. Vol. 2, No. 3, pp. 143-150, 2008

- [6]. A. Al-Anbuky and S. Bataineh Al-Aqtash, "Power demand prediction using fuzzy logic," *Control Engineering Practice*, Vol. 3, No. 9, pp. 1291-1298, 1995.
- [7]. A. Rajagopalan, G. Washington G. Rizzani and Y. Guezennec, "Development of Fuzzy Logic and Neural Network Control and Advanced Emissions Modeling for Parallel Hybrid Vehicles," Center for Automotive Research, Intelligent Structures and Systems Laboratory, Ohio State University, USA, December 2003.
- [8]. B. Cleveland and A. Meystel, "Dynamic predictive planning + fuzzy logic control = intelligent control," in Proceedings of the 1990 International Symposium on Intelligent Control, 1990.
- [9]. E. A. Glass and J. H. Painter, "Object-oriented design of discrete fuzzy control for aircraft flaps," in Proceedings of the 2nd International Workshop on Industrial Fuzzy Control and Intelligent Systems, College Station, TX, December 1992, pp. 108-112.
- [10]. V. Q. Harral, "Genetic algorithms for tuning fuzzy membership functions in flight control software, M.S. Thesis," Department of Electrical Engineering, Texas A&M University, College Station, TX, December 1995.
- [11]. M. Laviolette, J. W. Seaman, J. D. Barrett and W. H. Woodall, "A probabilistic and statistical view of fuzzy methods," *Technometrics*, vol. 37, no. 3, pp. 249-261, August 1995.
- [12]. T. H. Nguyen and D. T. Ward, "A neural-network based inference engine for a general aviation pilot advisor," Paper #97-0221 of the AIAA 35th Aerospace Sciences Meeting and Exhibit, Reno, NV, January 1997.
- [13]. J. H. Painter, D. T. Ward, J. W. Crump and W. W. Nash, "General aviation pilot advisory and training system," Final Report for Phase-1, Contract NAS1-20290, NASA Langley Research Center, Hampton, VA, 1995.
- [14]. M. D. Skidmore, J. P. Zenyuh, R. L. Small, T. J. Quinn and A.D. Moyers "Dual use applications of hazard monitoring: commercial and military aviation and beyond," in Proceedings of the IEEE/AESS/SAE National Aerospace & Electronics Conference, Dayton, OH, May 1995.
- [15]. J. A. Trang, "Automated safety and training avionics for general aviation aircraft," M.S. Thesis, Department of Electrical Engineering, Texas A&M University, College Station, TX, May 1997.
- [16]. K. P. Valavanis (Ed.), "Advances in Unmanned Aerial Vehicles State of the Art and the Road to Autonomy," *Springer*, Netherlands, 2007.
- [17]. T. Ören, "Prospected Airspace Management with Integration of Unmanned Systems," Second International Aviation Management Conference, Ankara, 2014.
- [18]. K. A. Bakare, "Design And Implementation Of A Fuzzy Logic Model For Air Traffic Control System," MSc Thesis, Ahmadu Bello University, Faculty Of Sciences, Department Of Mathematics, Nigeria, 2008.
- [19]. J. F. D'Arcy and P. S. D. Rocco, "Air Traffic Control Specialist Decision Making and Strategic Planning – A Field Survey," U.S. Department of Transportation Technical Note, 2001. Boeing Co., Statistical Summary of Commercial Jet Airplane Accidents Worldwide Operations 1959-2013, 2013.
- [20]. H. Tomaszek, M. Jaszal and M. Zieja, "A simplified method to assess fatigue life of selected structural components of an aircraft for a variable load spectrum," *Eksplotacja i Niezawodność – Maintenance and Reliability* 2011; 4: 29-34.
- [21]. M. R. Wolff and T. J. Mavin, "Assessment of Non-technical Skills: From Measurement to Categorization Modeled by Fuzzy Logic," *Aviation Psychology and Applied Human Factors*, 3, 73-82, 2013.
- [22]. Beasley JE, Chu PC. A Genetic Algorithm for the Set Covering Problem. *European Journal of Operational Research*, 94:392–404, 1996.
- [23]. Goumopoulos C, Alefragis P, Housos E. Parallel Algorithms for Airline Crew Planning on Networks of Workstations. In Proceedings of the International Conference on Parallel Processing, 1998.
- [24]. Uwe A. An Indirect Genetic Algorithm for Set Covering Problems. *Journal of the Operational Research Society*, 53:1118-1126, 2002.
- [25]. Ayag Z, Ozdemir RG. A fuzzy AHP approach to evaluating machine tool alternatives. *Journal of Intelligent Manufacturing*, 17, 179–190, 2006.
- [26]. Bureau of Transport and Communications Economics. The progress of aviation reform (Rep. No. 81). Canberra: Australian Government Publishing Service. p.34, 1993.
- [27]. Higgins AJ, Hajkowicz S, Bui, E. A multi-objective model for environmental investment decision making. *Computers and Operations Research*, 35(1), 253-266, 2008.
- [28]. Janic MAn assessment of risk and safety in civil aviation. *Journal of Air Transport Management*, 6, 43–50, 2000.
- [29]. Saaty TL, Vargas LG. Decision making with the analytic network process in economic, political, social and technological applications with benefits, opportunities, costs and risks (Vol. 95). Springer's International Series. doi:10.1007/0-387-33987-6, 2006.
- [30]. W. K. Lee and Y. H. Chang, "Applying the fuzzy FMECA to assess the risks of flight-safety," *Civil Aviation Journal*, vol. 7, pp. 1–22, 2005.
- [31]. O. Cokorilo, "Human factor modeling for fast-time simulations in aviation," *Aircraft Engineering and Aerospace Technology*. 85 (5) pp. 389- 405. DOI: 10.1108/AEAT-07-2012-0120, 2013.
- [32]. J. S. Carroll, J. W. Rudolph and S. Hatakenaka, "Learning from experience in high hazard organizations," *Research in Organizational Behavior*, 24, p. 87-137, 2002.
- [33]. A. Gregoriades and A. Sutcliffe, "Workload prediction for improved design and reliability of complex systems," *Reliability Engineering and System Safety*, doi:10.1016/j.res.2007.02.001, 2007.
- [34]. D. Hall, "The role of human factors training and error management in the aviation maintenance safety system," In: 58th Joint Meeting of the Flight Safety Foundation, 58TH Annual International Air Safety Seminar (IASS). November 2005. Moscow. p. 245-250, 2005.
- [35]. T. C. Hsia, "Evaluating the writing quality of aircraft maintenance technical orders using a quality performance matrix," *International Journal of Industrial Ergonomics*, 37, p. 605–613, 2007.
- [36]. H. A. Kinnison, "Aviation Maintenance Management," *McGraw Hill*. New York. USA, 2004.
- [37]. J. J. H. Liou G. H. Tzeng and H. C. Chang, "Airline safety measurement using a hybrid model," *Journal of Air Transport Management*, 13, p. 243–249, 2007.
- [38]. G. Quan, G. W. Greenwood, D. and S. Liu Hu, "Searching for multiobjective preventive maintenance schedules: combining preferences with evolutionary algorithms," *European Journal of Operational Research*, 177, p. 1969–1984, 2007.
- [39]. M. Sachon and P. Cornel, "Delays and safety in airlines maintenance" *Reliability Engineering and System Safety*, 67, p. 301–309, 2000.