

# Wireless Sensor Networks Application and Control in Industrial System: A Study Report

M.Chithik Raja

Salalah College of Technology- Oman  
Chithik25@gmail.com

**Abstract-**This Research article provides a application on implementing wireless sensor network (WSN) technology on industrial System monitoring and control. First, the existing industrial applications are explored, following with a review of the advantages of adopting WSN technology for industrial control. Then, challenging factors influencing the design and acceptance of WSNs in the process control world are outlined, and the state-of-the-art research efforts and industrial solutions are provided corresponding to each factor. Further research issues for the realization and improvement of wireless sensor network technology on systematic industry are also mentioned.

**Keywords-**wireless sensor Networks, Remote transducer, Wi-Fi, Topology, Control system

## 1 INTRODUCTION

This Research explored the various aspects on applications of WSNs in process industry. Also, there have been tremendous efforts toward the product research and development in industry. In addition to reviewing the recent research and development achievements, this paper will also analyse special issues for implementing WSN technology on industrial process monitoring and control. Wireless sensor network technology has demonstrated a great potential for industrial, commercial, and consumer applications. Specifically, in process monitoring and control, process data such as pressure, humidity, temperature, flow, level, viscosity, density and vibration intensity measurements can be collected through sensing units and transferred wirelessly to a control system for operation and management. Adopting WSNs for process monitoring and control provides great advantages over traditional wired system. As a ubiquitous technology, general issues regarding WSNs have been extensively researched in the academic arena. However, WSN technology is not considered mature enough to be widely implemented in process control applications. Even though wireless transmission of data has been utilized for over ten years in process control applications such as supervisory control and data acquisition (SCADA), industrial WSN products for process monitoring and control are not commercially available until recently due to its specific requirements and challenges.

## 2. WSN FOR PROCESS CONTROL

Algorithms used in the industrial factory for monitoring and control the activities of a specific process to achieve the goal. Let us explain this by illustrating a simple wired application. For example, cooling down a reactor by adjusting the flow rate through the cooling jacket is a process that has the specific, desired outcome to reach: maintaining a constant predefined temperature over time. As shown in Fig. 1, all the devices are hardwired together. Here, the temperature is the controlled variable. At the same time, it is the input variable since it is measured by a temperature sensor and used in a special function to decide the adjustment of a valve to manipulate the flow rate through the cooling jacket. The desired temperature is the set point. The valve opening position (e.g. the setting of the valve allowing cooling material to flow through it) is called the manipulated variable since it is subject to control actions. In practice, the temperature value is transmitted to the controller; the controller implements the functions and calculations, transmits the output to control the valve and issues alarm if there are faulty conditions. In the meantime, all data information can be archived for future reference when a review of process trends could provide additional

improvements. By utilizing WSN technology, sensing and action devices will communicate wirelessly with an access point (e. g., a gateway or router), which is connected to the control station wirelessly or through wired methods (e.g., Ethernet, Modbus). An example WSN application to replace the wired process control system in Fig. 1 is illustrated in Fig. 2. Most of the process control applications are mission critical and have stringent requirements. Failure of a control loop may cause unscheduled plant shutdown or even severe accidents in process-controlled plants.

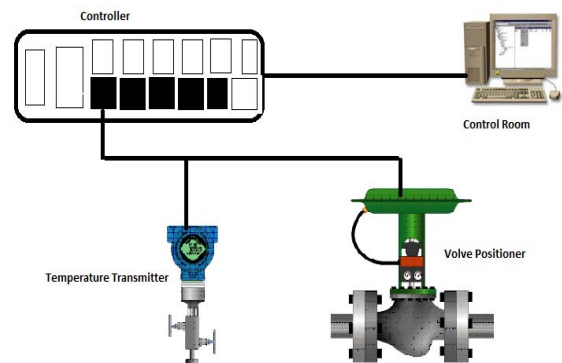

Fig.1 Model Process Control System

Even when tremendous researches have indicated the compelling benefits of adopting wireless communication technology combined with sensors, a cautious approach was adopted by the technology leaders due to a variety of challenges at the end-user level. The initial applications are mainly focused on process monitoring instead of closed-loop process control. Due to the stringent requirements for closed-loop control, it takes a long journey for the technology transit from wireless process monitoring and open-loop control to closed-loop control. It was pointed out in a report on wireless process control products from ISA (International Society of Automation)



Fig.2. WSN for Process Control

main stream process control devices such as temperature sensors, valves, and motors that are ready-equipped with wireless transmitters, common network standard and complete wireless process control systems were not yet available. Major achievements have been accomplished recently. Wireless HART (Wireless Highway Addressable Remote Transducer). An open-standard wireless networking technology developed by ISA, the ISA100.11a, has also been released for official description is "Wireless Systems for Industrial Automation: Process Control and Related Applications" Accompanying with these standards, there are emerging wireless process monitoring and control

systems together with the wireless transmission enabled main stream process monitoring and control devices. A list of commercial off-the-shelf sensor platforms can be found in. Some example WSN process monitoring and control devices and their specifications are listed in Table 1. There have been lots of successful applications all over the world. A wireless self-organizing mesh field network has been applied to monitor wellhead annular pressure and heat exchanger pressures on an offshore platform in the ocean. Even though the well head area is crowded with metal obstructions everywhere, remote monitoring is achieved successfully in this harsh, difficult to reach area. Continuous monitoring of pressures eliminates the need for daily visits to the wellhead to manually record gauge readings and enables unusual readings to be identified earlier and action taken to investigate and rectify faults before they develop into serious problems. What's more, the installation took about two hours compared with up to two days for a conventional wired installation. Another exciting application is the temperature monitoring on a rotating drier to ensure that the proper temperature is reached and maintained during the drying process. The cost of wiring for temperature measurement on a rotating drier is prohibitive. With the savings introduced by using wireless transmitters, more temperature transmitters can be located on each drum to increase the amount of process information. Additionally, the five year battery life for each unit lessens the need for periodic transmitter maintenance.

**Table1. WSN Products**

	Honeywell	Accutech	Emerson
Example application	Pressure, temperature, level, position measurement, discrete input/output	Pressure, temperature, level measurement, discrete input	Pressure, temperature, level, position, vibration measurement, discrete input
Communication Technology	Star Mesh Network – The Honeywell One Wireless network is formed with multi-protocol communication nodes, called multinodes, which support both 802.11 and field sensor-based transmissions.	Star Point to Point Communication – Base station that transmits and receives data from multiple field units	Mesh Network – The Dust Mesh network with self healing and self organization features.
Fastest Update Time	1 second	1 second	4 second
Transmission Technology	2.4 GHz Frequency Hopping Spread Spectrum (FHSS)	900MHz Frequency Hopping Spread Spectrum (FHSS)	2.4 GHz Direct Sequence Spread Spectrum (DSSS)
Number of Field Units per Network	Each multi node accepts signals from up to 20 wireless transmitters reporting at 1 second, and up to 400 transmitters reporting at slower rates.	Up to 100 wireless field units per base radio	Up to 100 devices for a single wireless gateway
Gateway Interface	802.11 Wi-Fi	Modbus	Ethernet, Modbus
Maximum Transmit/Receive Range	Up to 6 miles (10 km) multi node to multimode communication; sensor to multinode designed for over 2,000 ft (600m)	Up to 5000ft (~1500m)	200m
Wireless Standard	ISA100.11a	Uses proprietary protocol	WirelessHart

**3. CHALLENGES AND SOLUTIONS**

Even though adopting WSN technology to process control systems is attractive, there exists a lot of challenges. The transition from wire to wireless can be beneficial only if related issues are resolved by the combined efforts from both academy and industry.

**3.1 Quality of Service**

Process monitoring and control applications range from data sensing, measurement, record and diagnosis, to machine/equipment operation and emergency action. These operations are classified by the ISA100 committee into six different classes with increased priority as following :

Class 5: Monitoring without immediate operational consequences.

Class 4: Monitoring with short-term operational consequences

Class 3: Open-loop control

Class 2: Closed-loop, supervisory control

Class 1: Closed-loop, regulatory control

Class 0: Emergency action

Data communication in these process control applications includes continuous data request and asymmetric or spontaneous data traffic. For smooth operation, the major concern is the quality of service, which requires the correct data at the right time, i.e., the reliability of the data and the real-time guarantee. For the reliability of the data, challenges are coming from poor quality radio frequency (RF) links due to high noise, low signal due to lack of power, long path lengths or obstacles, multipath fading, or interference. For example, machines such as vibrator, motors and actuators in the factory can produce a significant amount of electromagnetic noise. Interference or noise in the same frequency band from other sources can corrupt or even eliminate the data signal. The changing radio conditions introduce uncertainties on data packets loss and transmission delay. The following actions can be taken to improve the accuracy, integrity, and freshness of data.

Radio transmission technology: For physical layer radio transmission, the Direct Sequence Spread Spectrum (DSSS) or Frequency Hopping Spread Spectrum (FHSS) technology has been utilized to significantly reduce noise interference. DSSS transmits data by spreading out over a wide frequency range. It avoids interference by configuring the spreading function in the receiver to concentrate the desired signal but spread out and dilutes any interfering signal. While FHSS transmits data in a narrow frequency that “hops” around a wide frequency band. It avoids interference that occurs at a particular frequency.

Using spread spectrum significantly increases the reliability that the correct data is received even in high noise environments. Also, higher gain or directional antenna can be used to improve signal strength. Diversity technique: Different radios may be utilized for operation of various ranges. Also, a sensor’s radio transceiver can be capable of changing its transmission power to achieve different transmission ranges. Multi-path technique: Signals may be routed/relayed through multiple wireless nodes. In mesh network, multiple paths are used for delivery a single message to guarantee its reliability to 99.9%. For example, if one path is block by obstacle (e. g., a driving by track), the data can still be transmitted through other paths.

Synchronization and identification technique: Time synchronization techniques are used to synchronize all the nodes by time-stamping the data with a global clock. For special application, the process data is also location-stamped . Evaluation and estimation technique

A WSN self-test technique is introduced to deal with the dynamic RF environment. It indicates that unlike wired channels, where errors come from faulty cables, connector or other hardware components are persistent, transmission errors on wireless channels tend to be transient. By evaluating parameters from a feedback loop, the RF environment characteristics can be estimated and they are used to predict the performance and adapt the operational characteristics of the WSNs to meet the specific application goal. advocates the use of model predictive control (MPC) algorithm to tackle the challenges arises from the usage of wireless technology within feedback control loops. The MPC control algorithm provides an optimized sequence of future control moves based on the process dynamics model, system variable constraints, desired performance specifications, current state and future prediction. Simulation results prove that it can handle certain packet lose in both forward and feed back

communication links and it is easy to tune. The drawback is that hybrid MPC is computational intense, so that a time constraint on the optimization solver is necessary to bound the worst-case computation period. Redundant technique: Components in WSN can be redundant to increase its reliability, for example, dual gateways are highly recommended for increased reliability. Also, if we can use two or more different frequencies to communicate at the same time, data transmission will continue even if there is interference on one of the frequencies. Besides reliability requirements, industrial process control also has stringent real-time requirements. As shown in Fig. 1, the real time temperature information is used to decide further operation of the valve positioner. For time critical applications, excessive delay may cause overshoot or disturbance to the process. Analysed the requirements of control system and proposed to use scheduling tool to control the traffic and to limit the retransmission in order to meet this need. To deal with complex control systems that consist of operations of different classes as we introduced before, priority based methods should be adopted to manage the data transmission. Instead of treating this problem directly, there are also work-around methods. For example, multiple transmission capabilities can be incorporated into a single device. For time critical tasks, devices can switch to high speed mode to transmit message by just one hop. Control in the field can also be used to avoid delay. As shown in Fig. 1, in traditional control systems, information is collected and transmitted to controller; the controller makes the decision and transmits the command to operate the devices. Instead of transmitting signals back and forth to/from controllers, which is usually located remotely, sensing devices can transmit the signals to a highly intelligent device, where the decision is made locally and actions are taken immediately. In the meantime, the results are transmitted to the control room for monitoring and recording.

A machine-to-machine application is proposed in which claims to cover a wide range of applications. A typical scenario is that a sensor detects an anomaly, sends an alert to a monitoring middleware which in turn generates a command to an actuator, informs a business operation software application, and eventually sends an alarm to an operator off the loop. A method of transmitting directly to control system instead of the controller is also proposed. In addition to all the above mentioned pro-active preventive or active actions to improve quality of service, post-active countermeasures are also carried out if node failure and package loss arises. Responsive actions must be taken immediately to preclude the failure of certain sensor nodes from affecting the overall task of the sensor network. These actions include implementing fault tolerance methods, formatting new routing path, adjusting of transmission power and sampling rates, commissioning device into fail-safe mode, etc. A novel scheme for detection of faulty sensors is proposed in. In a fault tolerance by quartile method (FTQM) is proposed. In FTQM, the sensing data is firstly divided into four regions. Then, FTQM modifies the region range to select the correct data based on data discreteness. Hence, actors could perform the appropriate actions proposed to implement a learning and refinement module which enables a fault tolerance solution to be adaptive and self-configurable based on changes in the network conditions.

#### 4. NETWORK TOPOLOGY

The network topology is the backbone for any network based systems. When choosing the communication topology for a WSN, in addition to the responsiveness and reliability discussed in Section 4.1, the following aspects need to be considered according to different scenarios: connectivity, adaptability, mobility, and scalability. For example, how to preclude isolated nodes? How does the system adapt to changing RF environments, and loss of key components such as routing nodes and gateways? How does the system support mobile devices such as the handheld field configurator?

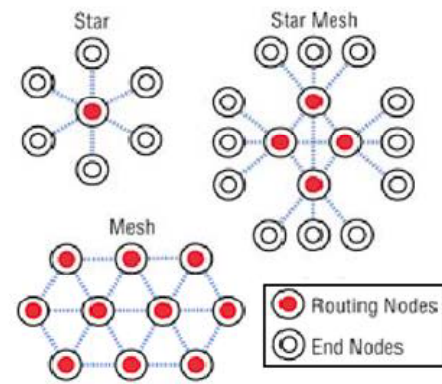

Figure 3. Network Topology

As shown in Fig. 3, there exist three types of network topology for industrial WSN applications: star, star mesh and mesh. In star network, each node has a designated forwarding path. If there is a failure between two nodes, the information is lost, so that site surveys and link-level configuration are performed during system installation. Compared to star network, star mesh network has increased adaptability, mobility, and scalability by providing multiple routing nodes but they do not offer full end-to-end redundancy. In mesh network, each end nodes are also routing nodes, so that all nodes are fully connected to provide full redundancy. As we discussed signals are transmitted from source to sink through multiple paths; if failure happens in one path, the information can still be obtained through other paths. The self organizing and self healing features make the mesh network highly adaptive to node failures/relocation and easily scalable for network expanding. Only for mesh network can a new node be added anywhere without sophisticated site surveys as long as it is within transmission range of at least two other nodes. It requires less manual configurations for each node and provides greater expandability when more nodes are to be added in the future. This makes it a more suitable choice for deployments that are subjected to changes. The drawback is that extra delay and processing time is introduced due to multiple hops and paths.

#### 5. RESOURCES

The architecture of a wireless node for process monitoring and control is shown in Fig. 4. For the design of this device, there exist multiple resource limitations, such as processing power and memory limitation, bandwidth limitation, and constrained energy capacity.

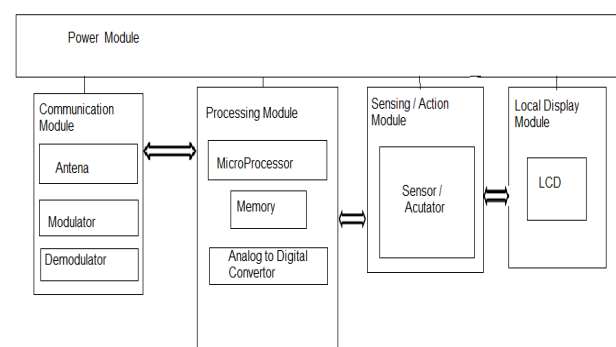

Fig.4. The architecture of a wireless node for process monitoring and control

Hardware limitation: As shown in Fig. 4, the processing module supports the operation system, the network protocol, and handles the data processing and control algorithms. The selection of the microprocessor is critical to the whole design. The ideal microprocessors are those that have large memory and powerful computation capability, consume ultra-low power, and are also energy efficient. An introduction and comparison of available microcontrollers can be found in provides an interesting heterogeneous multiprocessor sensor node with staged wakeup to keep the device energy efficient. As the technology advances, it is promising to have powerful processor and large memory in the sensor nodes with reduced cost. Bandwidth limitation: Sensor nodes may provide



significant redundant data, for example, multiple signals generated from two or more temperature monitoring nodes, or from different sampling period of the same sensing unit. Similar data information can be aggregated by certain functions such as duplicate suppression, minima, maxima, and average to reduce the number of transmissions. Thus, data aggregation is a good technique to achieve required network capacity within the limited bandwidth. By aggregating multiple packets into one packet, the network through will be increased with the reduced overhead for each packet, the drawback is that may introduce extra delay. Coding is also applied in data transmission to increase network capacity. Furthermore, it is mentioned in that instead of transmitting the raw data, only the processed data such as estimation results are transmitted over the WSNs. Energy limitation: Power consumption remains to be the performance limiting factor and the biggest concern for WSNs. Currently, most industrial applications claim battery life of about five years and WSN systems are not viable in applications that require relatively large amounts of power. Although WSN systems can be applicable in high power applications if a wired power source is run to the devices, it is not preferred or feasible for most applications, where the sensing nodes can only be powered by batteries. A few current solutions are listed as following:

- 1) Energy efficient transmission: Since fewer data packets and less frequent transmission can save battery power, event-driven energy efficient method aims to reduce power usage by utilizing small data packets and only transmitting when parameters change. Moreover, nodes can operate with a very small duty cycle to conserve power. In other words, they are as inactive as possible for as long as possible.
- 2) Variable transmission range: Some researchers investigated energy saving by adjusting the transmission range. For example, an energy-balanced consumption scheme by varying the transmission ranges of sensors is proposed in. And an algorithm to search for an optimal transmission range to minimize the total power consumed by the topology management as well as data transmission is introduced in
- 3) Energy aware protocols: Energy aware protocols have been explored extensively in the literature. To list a few, a reliable energy aware routing (REAR) protocol for wireless sensor networks is introduced in. REAR considers residual energy capacity of each sensor node in establishing routing paths and supports multi-path routing protocol for reliable data transmission. An energy aware routing protocol for real time traffic in wireless sensor networks is proposed in to consider both energy and delay metric to find an optimal path with minimum energy consumption and minimum end to end delay.
- 4) Energy harvesting techniques: In addition to battery power, other power technologies such as solar power and energy harvesting from vibrations, blasts of radio can also be used to extend the WSN lifetime.

## 6. IMPLEMENTATION

End users are reluctant to choose wireless products due to their concerns on other important issues such as: coverage, interoperability, compatibility, serviceability, longevity, coexistence, availability, delivery and price. Coverage: For process monitoring, each sensor node obtains information for a limited physical area, so that a given sensor's measurement is limited in both range and accuracy. Careful placement of sensors is required for a full coverage of the field. For the scenario that multiple types of sensors are integrated for monitoring various aspects of a process, and redundant sensing nodes are deployed to tackle adverse environmental conditions such as obstacles and noise, an efficient deployment of sensors is preferred to guarantee the coverage and avoid wasting of sensing units. Here are a few interesting researches in the literature. A grid-based algorithm is proposed in In this research, the number of the selected sensor nodes is firstly determined based on the probability theory, then an effective selection algorithm is established.

Aiming at ensuring successful data delivery, coverage and connectivity in a network for a given lifetime, a novel density-varying deployment scheme for powerful high-end sensors in a heterogeneous sensor network is proposed and optimal placement of high-end sensors whose locations are controllable is studied in. Interoperability: A process monitoring and control project may require products from different suppliers for different functions such as monitoring on temperature, pressure, or level, control for valve, actuator, vibrator, etc. As there are a variety of WSN products available, interoperability is a must-have characteristic. Compatibility: Backward/forward compatibility is a good feature for possible upgrading and performance improvement. Some users may want to make use of existing infrastructure or products, so that product such as adapters from Hart to Wireless Hart is developed. Serviceability: Industrial devices are designed to meet strict requirements to be able to qualify for a variety of hazardous area certifications (flameproof/explosion proof/non-incentive /intrinsically safe). For example, a lot of industrial applications require the product to be intrinsic safe for operation of electronic equipment in explosive atmospheres. This is achieved by ensuring low voltages and currents. Battery powered WSN products are a good fit for these applications. Longevity: Process control applications range from general purpose application in ordinary locations to special operation in hazardous area under harsh environment. So that devices are engineered to a high level to survive in extremely hot, cold, wet, dirty, abusive, corrosive, and explosive environments. Electronic components are usually encapsulated or fully covered for protection. Devices must undergo various tests such as lifecycle test, vibration test, and temperature test before release to market. Due to the tough environment, the hard to reach location and the requirement for the long-term continuous operation, frequent battery change is not recommended. Then energy capability for battery powered devices becomes a major concern. Coexistence: During implementation, users will also pay attention to coexistence issues to avoid possible interference with existing wireless equipment and to reduce signal interference between WSN nodes. Availability, delivery and price: WSNs for process monitoring and control are gaining more attention in industry. Some of the potential users may be still waiting to see which standard or product will prevail, but others are already taking actions. Lots of case study for successful WSNs for process monitoring and control applications can be found online. With the increasing market needs, capital investment and mass production, there will be better availability, faster delivery and decreased price for WSN products.

## 7. LINK LAYER AND NETWORK LAYER PROTOCOLS

When designing network protocols for wireless sensor networks, several factors should be considered. First and foremost, because of the scarce energy resources, routing decisions should be guided by some awareness of the energy resources in the network. Furthermore, sensor networks are unique from general ad hoc networks in that communication channels often exist between events and sinks, rather than between individual source nodes and sinks. The sink node(s) are typically more interested in an overall description of the environment, rather than explicit readings from the individual sensor devices. Thus, communication in sensor networks is typically referred to as data-centric, rather than address-centric, and data may be aggregated locally rather than having all raw data sent to the sink(s). These unique features of sensor networks have implications in the network layer and thus require a re-thinking of protocols for data routing. In addition, sensors often have knowledge of their own location in order to meaningfully assess their data. This location information can be utilized in the network layer for routing purposes. Finally, if a sensor network is well connected (i.e., better than is required to provide communication paths), topology control services should be used in conjunction with the normal routing protocols. Some of the work has been done to address these sensor network-specific issues in the routing layer. These protocols can be classified into three

classes: Resource-Aware Routing Data-Centric Routing Geographic Routing Clustering for Data Aggregation Querying a Distributed Database Topology Control . Medium Access Control (MAC) protocols designed for typical ad hoc networks have primarily focused on optimizing fairness and throughput efficiency, with less emphasis on energy conservation. However, energy constraint is typically considered paramount for wireless sensor networks. It has been shown that idle power consumption can be of the same order as the transmit and receive power consumption. The focus of most MAC protocols for sensor networks is to reduce the idle power consumption by setting the sensor radios into a sleep state as often as possible. Sensor-MAC (S-MAC) , Timeout-MAC (T-MAC), DMAC, TRaffic-Adaptive Medium Access (TRAMA) Sparse Topology and Energy Management (STEM) are a few examples of these protocols.

### 8. SECURITY

Security is also of major concern for WSN applications in process industry. Attacks varies from eavesdropping on transmissions including traffic analysis or disclosure of message contents, to modification, fabrication, and interruption of the transmissions through node capturing, routing attacks, or flooding. When designing the security mechanisms, both low-level (key establishment and trust control, secrecy and authentication, privacy, robustness to communication denial-of-service, secure routing, resilience to node capture) and high-level (secure group management, intrusion detection, secure data aggregation) security primitives should be addressed. It is reported that this issue is well addressed with existing standards-based technologies. Breaches in security policies are almost technically impossible unless caused by unavoidable issues such as disgruntled employees, theft of access passwords, or bad configuration of the network. AES-128 (Advanced Encryption Standard, with 128-bit keys and 128-bit block size) symmetric-key cryptography algorithm is used in the IEEE 802.11 and IEEE 802.15.4 standards. In WirelessHart, this algorithm is used in conjunction with other security services such as key management (rotating keys for added security), data authentication (for detecting modified data), data freshness service (to avoid replay attacks). to provide a complete solution with an equivalent or higher level of security performance than that provided by wired systems. The ZigBee protocol also defines methods for implementing security services such as cryptographic key establishment, key transport, frame protection, and device management.

### 9. CONCLUSIONS

WSN is a technology with promising future and it is presently used in a wide range of applications to offer significant advantages over wired system. However, WSN technology is not considered mature enough to be widely implemented in process control applications. The demanding constraints for process monitoring and control applications pose many challenges to the implementation of WSNs to the industrial

field. In this paper we have surveyed various issues relating to implementing the WSN technology to process monitoring and control. Future research and development may continue to be focused on further improvements of the reliability and responsiveness, and technology advancements on energy saving, power management, fault tolerance, and smart routing. It may also be commercialized as an add-on software component to evaluate the overall system performance, predict potential problem, and provide suggestions for meeting the desired customer selectable criteria based on the existing system performance. Also, control over wireless is still an emerging research area. The usage of WSN technology within feedback control loops raises lots of challenges to be explored.

### REFERENCES

- [1]. Mattison, D.W., Jeffries, J.B., Hanson, R.K., Steeper, R.R., DeZilwa, S., Dec, J.E., Sjoberg, M., Hwang, "In-cylinder gas temperature and water concentration measurements in HCCI engines using a multiplexed-wavelength diode-laser system: sensor development and initial demonstration," Proc. Combustion Institute (2006) in press.
- [2]. Klingbeil, A.E., Jeffries, J.B., Hanson, R.K., "Tunable mid-IR laser absorption for time-resolved hydrocarbon fuel measurements," Proc. Combustion Institute **31** (2006) in press.
- [3]. J. Yick, B. Mukherjee and D. Ghosal, "Wireless Sensor Network Survey", Science Direct-Computer Networks, Vol. 52, Issue 12, pp. 2292-2330, 22-2008.
- [4]. I. F. Akyildiz, W. Su, Y. Sankarasubramaniam, and E. Cayirci, "A Survey on Sensor Networks", IEEE Communication Magazine, vol. 40, no. 8, pp. 102-114, 2002.
- [5]. E. Deborah, G. Ramesh, H. John, and K. Satish, "Next century challenges: scalable coordination in sensor networks," in proceedings of the 5th annual ACM/IEEE international conference on Mobile computing & networking Seattle, Washington, United States: ACM Press, pp. 263-270, 1999.
- [6]. D. Puccinelli and M. Haenggi "WSN: Applications & Challenges", CAS Magazine, sept. 2005.
- [7]. L. Schwiebert, K. S. Gupta, and J. Weinmann, "Research challenges in wireless networks of biomedical sensors", In Mobile Computing and Networking, pp 151-165, 2001.
- [8]. M. B. Srivastava, R. R. Muntz, and M. Potkonjak, "Smart kindergarten: sensor-based wireless networks for smart development a problem-solving environments", In Mobile Computing and Networking, pp 132-138, 2001.
- [9]. Von Drasek, W., Wehe, S., Allen, M., Laser-based multiple gas species sensor for harsh combustion process control applications, Trends in Optics and Photonics, Conference on Lasers and Electro- Optics,
- [10]. C. Falcon "Wireless medical devices: Satisfying radio requirements. Medical Device & Diagnostic Industry", page 80, September 2004. URL: <http://www.devicelink.com/mddi/archive/04/15,2004>.
- [11]. Population Projections Branch U.S. Census Bureau, Population Division. National population projections. population pyramid
- [12]. National Association for Home Care. Basic statistics about home care 2001. URL: <http://www.nahc.org/Consumer/hcstats.html>, visited Oct. 12, 2004.
- [13]. N. WANG, M. H. Wang, and N. Q. Zhang, "Wireless sensors in agriculture and food industry: Recent development and future perspective," Computers and electronics in agriculture, vol. 50, no. 1, pp.1-14, 2006.
- [14]. D. Pimentel, J. Houser, E. Preiss, O. White, H. Fang, L. Mesnick, T. Barsky, S. Tariche, J. Schreck, and S. Alpert, "Water Resources: Agriculture, the Environment, and Society", vol. 47, no. 2, pp. 97-106, Feb. 1997.
- [15]. O. Nino-Fluck, "Geoinformation and Sustainable Land Management," Conference for Africa and The Middle East, Rabat, Morocco, Oct. 2000.