

# Application of PI, Fuzzy Logic and ANN in Improvement of Power Quality using Unified Power Quality Conditioner

K.S. Ravi Kumar<sup>#</sup>, S.V.A.R.Sastry<sup>\*</sup>

<sup>#</sup> *Electrical Engineering Dept., M.V.G.R.College of Engineering,Vizianagaram, Andhra Pradesh, India*

<sup>\*</sup> *Chemical Engineering Department,M.V.G.R. College of Engineering.Vizianagaram, Andhra Pradesh, India.*

**Abstract**— The unified power quality conditioner (UPQC) is being used as a universal active power conditioning device to mitigate both current and voltage harmonics at a distribution side of power system network. This paper emphasis enhancement of power quality by using UPQC with fuzzy logic controller (FLC) and proportional-integral (PI) controller. The main purpose of the proposed (FLC) is capable of providing good static and dynamic performances compared to PID controller.

**Keywords**— UPQC, Fuzzy, ANN, PQ, THD.

## I. INTRODUCTION

With the advent of power semiconductor switching devices, like thyristors, GTO's (Gate Turn off thyristors), IGBT's (Insulated Gate Bipolar Transistors) and many more devices, control of electric power has become a reality. Such power electronic controllers are widely used to feed electric power to electrical loads, such as adjustable speed drives (ASD's), furnaces, computer power supplies, HVDC systems etc.

The power electronic devices due to their inherent non-linearity draw harmonic and reactive power from the supply. In three phase systems, they could also cause unbalance and draw excessive neutral currents. The injected harmonics, reactive power burden, unbalance, and excessive neutral currents cause low system efficiency and poor power factor. In addition to this, the power system is subjected to various transients like voltage sags, swells, flickers etc. These transients would affect the voltage at distribution levels. Excessive reactive power of loads would increase the generating capacity of generating stations and increase the transmission losses in lines. Hence supply of reactive power at the load ends becomes essential.

Power Quality (PQ) has become an important issue since many loads at various distribution ends like adjustable speed drives, process industries, printers, domestic utilities, computers, microprocessor based equipments etc. have become intolerant to voltage fluctuations, harmonic content and interruptions.

Power Quality (PQ) mainly deals with issues like maintaining a fixed voltage at the Point of Common Coupling (PCC) for various distribution voltage levels irrespective of voltage fluctuations, maintaining near unity power factor power drawn from the supply, blocking of voltage and current unbalance from passing upwards from various distribution levels, reduction of voltage and current harmonics in the system and suppression of excessive supply neutral current.

Conventionally, passive LC filters and fixed compensating devices with some degree of variation like thyristor switched capacitors, thyristor switched reactors were employed to improve the power factor of ac loads. Such devices have the demerits of fixed compensation, large size, ageing and resonance. Nowadays equipments using power semiconductor devices, generally known as active power filters (APF's), Active Power Line Conditioners (APLC's) etc. are used for the power quality issues due to their dynamic and adjustable solutions. Flexible AC Transmission Systems (FACTS) and Custom Power products like STATCOM (STATIC synchronous COMPensator), DVR (Dynamic Voltage Restorer), etc. deal with the issues related to power quality using similar control strategies and concepts. Basically, they are different only in the location in a power system where they are deployed and the objectives for which they are deployed.

### UPQC:

Active Power Filters can be classified, based on converter type, topology and the number of phases. Converter types are Current Source Inverter (CSI) with inductive energy storage or Voltage Source Inverter (VSI) with capacitive energy storage. The topology can be shunt, series or combination of both. The third classification is based on the number of phases, such as single phase systems, three phase systems or three phase four wire systems.

The Objective of this paper, one such APFC known as Unified Power Quality Conditioner (UPQC), which can be used at the PCC for improving power quality, is designed, simulated using proposed control strategy and the performance is evaluated for various nonlinear loads (steel plant loads).

Unified Power Quality Conditioner (UPQC) using PLL with PWM Control is discussed and simulated. Case study of a typical steel plant has been given. Simulated proposed UPQC for various non-linear loads of steel plant and results with installation of STATCOM and UPQC are reported.

## II. OPERATION

Loads, such as, diode bridge rectifier or a thyristor bridge feeding a highly inductive load, presenting themselves as current source at point of common coupling (PCC), can be effectively compensated by connecting an APF in shunt with the load [4-6]. On the other hand, there are loads, such as Diode Bridge having a high dc link capacitive filter. These types of loads are gaining more and more importance mainly in forms of AC to DC power supplies and front end AC to DC converters for AC motor drives.

For these types of loads APF has to be connected in series with the load [4, 6].

The voltage injected in series with the load by series APF is made to follow a control law such that the sum of this injected voltage and the input voltage is sinusoidal. Thus, if utility voltages are non-sinusoidal or unbalanced, due to the presence of other clients on the same grid, proper selection of magnitude and phase for the injected voltages will make the voltages at load end to be balanced and sinusoidal.

The shunt APF acts as a current source and inject a compensating harmonic current in order to have sinusoidal, in-phase input current and the series APF acts as a voltage source and inject a compensating voltage in order to have sinusoidal load voltage. The developments in the digital electronics, communications and in process control system have increased the number of sensitive loads that require ideal sinusoidal supply voltage for their proper operation. In order to meet limits proposed by standards it is necessary to include some sort of compensation. In the last few years, solutions based on combination of series active and shunt active filter have appeared [1-3]. Its main purpose is to compensate for supply voltage and load current imperfections, such as sags, swells, interruptions, imbalance, flicker, voltage imbalance, harmonics, reactive currents, and current unbalance [10-16]. This combination of series and shunt APF is called as Unified Power Quality Conditioner (UPQC).

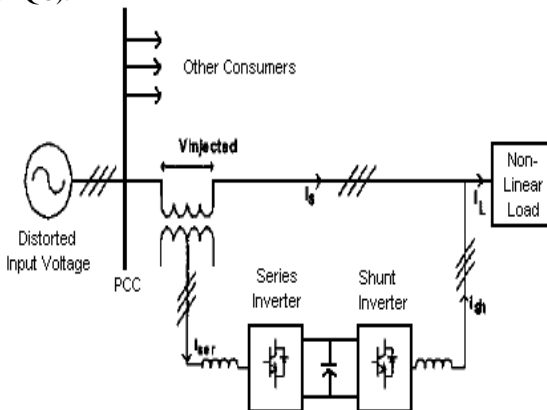

Fig1: Unified Power Quality Conditioner

**Reference generation (Phase Locked Loop):**

Reference currents and voltages are generated using Phase Locked Loop (PLL).

The control strategy is based on the extraction of Unit Vector Templates from the distorted input supply. These templates will be then equivalent to pure sinusoidal signal with unity (p.u.) amplitude.

The 3-ph distorted input source voltage at PCC contains fundamental component and distorted component. To get unit input voltage vectors  $U_{abc}$ , the input voltage is sensed and multiplied by gain equal to  $1/V_m$ , where  $V_m$  is equal to peak amplitude of fundamental input voltage. These unit input voltage vectors are taken to phase locked loop (PLL). With proper phase delay, the unit vector templates are generated.

$$\begin{aligned} U_a &= \text{Sin}(wt) \\ U_b &= \text{Sin}(wt-120) \end{aligned} \quad (1)$$

$$U_c = \text{Sin}(wt+120)$$

Multiplying the peak amplitude of fundamental input voltage with unit vector templates of equation (1) gives the reference load voltage signals,

$$V_{abc}^* = V_m \cdot U_{abc} \quad (2)$$

In order to have distortion less load voltage, the load voltage must be equal to these reference signals. The measured load voltages are compared with reference load voltage signals. The error generated is then taken to a hysteresis controller to generate the required gate signals for series APF.

The unit vector template can be applied for shunt APF to compensate the harmonic current generated by non-linear load. The shunt APF is used to compensate for current harmonics as well as to maintain the dc link voltage at constant level. To achieve the abovementioned task the dc link voltage is sensed and compared with the reference dc link voltage. A PI controller then processes the error. The output signal from PI controller [5] is multiplied with unit vector templates of equation (1) giving reference source current signals. The source current must be equal to this reference signal. In order to follow this reference current signal, the 3-ph source currents are sensed and compared with reference current signals. The error generated is then processed by a hysteresis current controller with suitable band, generating gating signals for shunt APF.

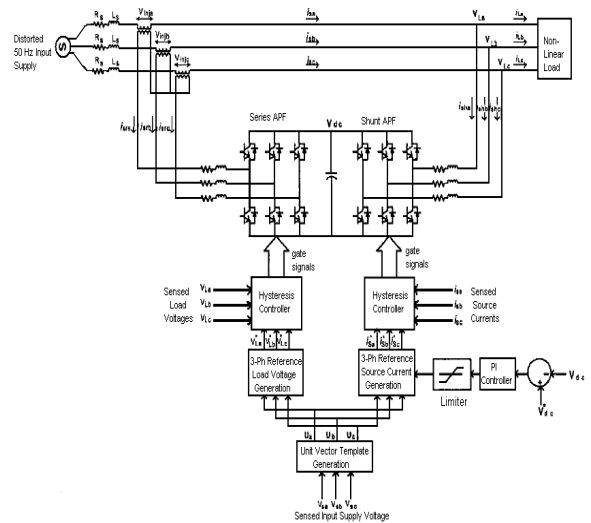

Fig2: Block diagram of UPQC

**III. FUZZY CONTROLLER**

The structure of a complete fuzzy control system is composed from the following blocks: Fuzzification, Knowledge base, Inference engine, Defuzzification. The fuzzification module converts the crisp values of the control inputs into fuzzy values. A fuzzy variable has which are defined by linguistic variables (fuzzy sets or subsets) such as low, Medium, high, big, slow where each is defined by a gradually varying membership function. In fuzzy set terminology, all the possible values that a variable can assume are named universe of discourse, and the fuzzy sets (characterized by membership function) cover whole universe of discourse. The shape fuzzy sets can be triangular, trapezoidal, etc. To verify the performance of UPQC the system was simulated using Simulink Power System Blockset in Matlab. The

above-mentioned analysis and design was done in continuous domain.

To verify the performance of UPQC the system was simulated using Simulink Power System Blockset in Matlab. The above-mentioned analysis and design was done in continuous domain. However, to investigate the behavior of the system with digital based controller in future experimental work, the UPQC system was simulated in discrete domain. All the compensators are implemented using equivalent discrete blocks. The compensator output depends on input and its evolution.

Fuzzy membership functions between 6 inputs as three phase currents and three phase voltages from input and two outputs as output voltage and current shown in below fig.6. Fuzzy rules are written between error and change of error for one particular quantity based on that that given voltage or current as its output, like that 49 rules are framed

**Table 1: Linguistic Rule Table**

Error de/dt	NL	NM	NS	Z	PS	PM	PL
NL	NL	NL	NL	NL	NM	NS	Z
NM	NL	NM	NM	NM	NS	Z	PS
NS	NL	NM	NS	NS	Z	PS	PM
Z	NL	NM	NS	Z	PS	PM	PL
PS	NM	NS	Z	PS	PS	PM	PL
PM	NS	Z	PS	PM	PL	PL	PL
PL	Z	PS	PM	PL	PL	PL	PL

**Matlab/Simulink Model:**

The Sim Power Systems (SPS) Matlab/Simulink based simulation model of proposed UPQC is realized . The load is realized by using a diode bridge rectifier followed by a RL load. The distortion in the supply voltage is introduced by connecting a 5<sup>th</sup> (20% of the fundamental input) harmonic voltage sources in series with the utility voltage. Both the series and shunt APF's are realized by six IGBT switches each, sharing a common dc. Link

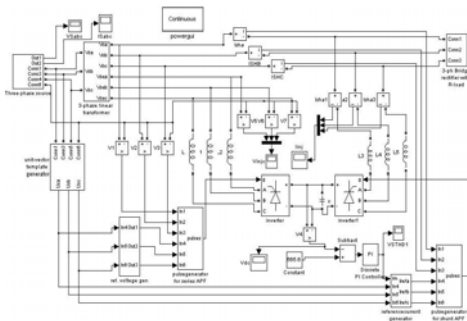

**Fig3: Simulink model of upqc with PI controller**

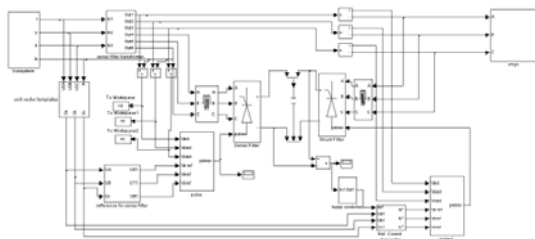

**Fig 4: Simulink model of upqc with fuzzy controller**

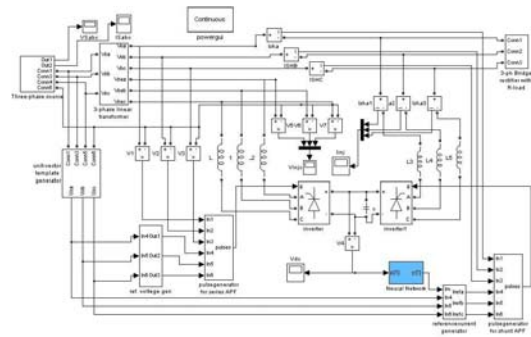
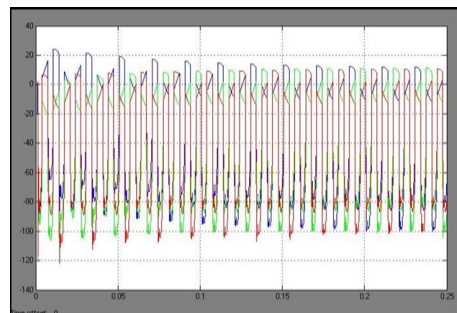

**Fig 5: Simulink model of upqc with ANN controller**

**IV. SIMULATION RESULTS**

To verify the operating performance of the proposed UPQC, a 3-phase electrical system, a PLL extraction circuit with hysteresis controlled UPQC is simulated using MATLAB software.

The simulation results are shown in the Fig. Both the series and shunt APF's are put into the operation at different time instant. First series APF put into the operation at a simulation time of 0.1 sec. At time 0.2 sec. shunt APF is put into the operation, such that both series and shunt APF's are operated as UPQC.. It should be noted that, in spite of distorted voltage at PCC, the unit vector template is pure sinusoidal because of use of PLL. Before time '0.1 Sec.' when both APF's are not in operation the load voltage is equal to the distorted input voltage deliberately consisting of 5th and 7th order voltage harmonics. As soon as series APF is put into the operation at instant '0.1 sec.', immediately it starts compensating the load voltage by injecting sum of 5th and 7th harmonic voltage through series line transformer, such that the load voltage is perfectly sinusoidal, The voltage injected by the series APF which is nothing but the sum of 5th (20%) harmonic voltages in the supply.



**Fig 5: voltage graph THD of PI controller**

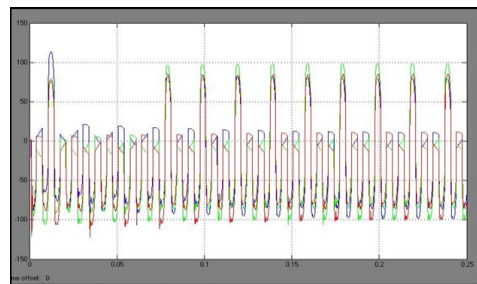

**Fig 6: voltage graph THD of FUZZY controller**

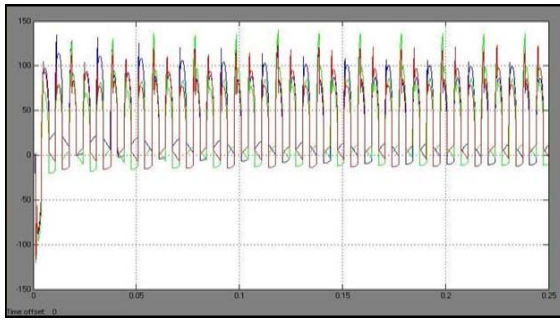

**Fig 7: voltage graph THD of ANN controller**

**Table 2: Comparison of total harmonic distortion**

HARMONIC ORDER/THD	WITH UPQC PI(Vs)	WITH UPQC FUZZY (Vs)	WITH UPQC ANN (Vs)
3 <sup>rd</sup> & 5 <sup>th</sup>	10.03	10.02	10.0
5 <sup>th</sup> & 7 <sup>th</sup>	9.95	9.94	9.94

#### V. CONCLUSION

UPQC performance mainly depends upon how accurately and quickly reference signals are derived. By using conventional Akagi's principle reference signals was derived. The simulated result shows that it has considerable response time for yielding effective compensation in the network. This may not be desirable in modern power system control. Using conventional compensator data, a fuzzy logic controller (FLC) is tuned with large number of data points. Then conventional compensator was replaced with fuzzy logic controller and simulated using Matlab/simulink for R-L load using uncontrolled rectifier. The simulation results have shown

that the UPQC perform better with FLC. Proposed scheme eliminates both voltage as well as current harmonics effectively. The ANN controller also performs in a similar way with slightly better voltage compensation. It is also observed that the response time for derivation of compensation signals reduces significantly with improved accuracy.

#### REFERENCES

- [1] Fujita, H. and Akagi, H. (1996) „The unified power quality conditioner: the integration of series active filter and shunt active filters”, Proceedings on IEEE/PES Power Electronics Specialist Conferences, June, pp.491–501.
- [2] Hirofumi Akagi, Fellow, New trends in Active Power filters for power conditioning, IEEE transactions on industry applications, vol 32, no 6, November 1996
- [3] Hirofumi Akagi, Trends in Active Power Line Conditioners, IEEE Tran. Power Electronics, vol. 9, no.3, May 1994, pp. 263-268.
- [4] Moleykutty George, Artificial Intelligence Based Three-Phase Unified Power Quality Condition, Journal of Computer Science 3 (7): 465-477, 2007 ISSN 1549-3636 © 2007 Science Publications
- [5] R.V.D. Rama Rao and Subhransu Sekhar Dash, Power Quality Improvement by using Unified Power Quality Conditioner with PID and Fuzzy Logic Controller, International Journal of Electronic Engineering Research ISSN 0975 - 6450 Volume 2 Number 5 (2010) pp. 663–676 © Research India Publications.
- [6] R V D Rama Rao, Dr.Subhransu Sekhar Dash, Enhancement of Power Quality by using Unified Power Quality Conditioner with PID and Fuzzy Logic Controller, International Journal of Computer Applications (0975 – 8887) Volume 5– No.7, August 2010